

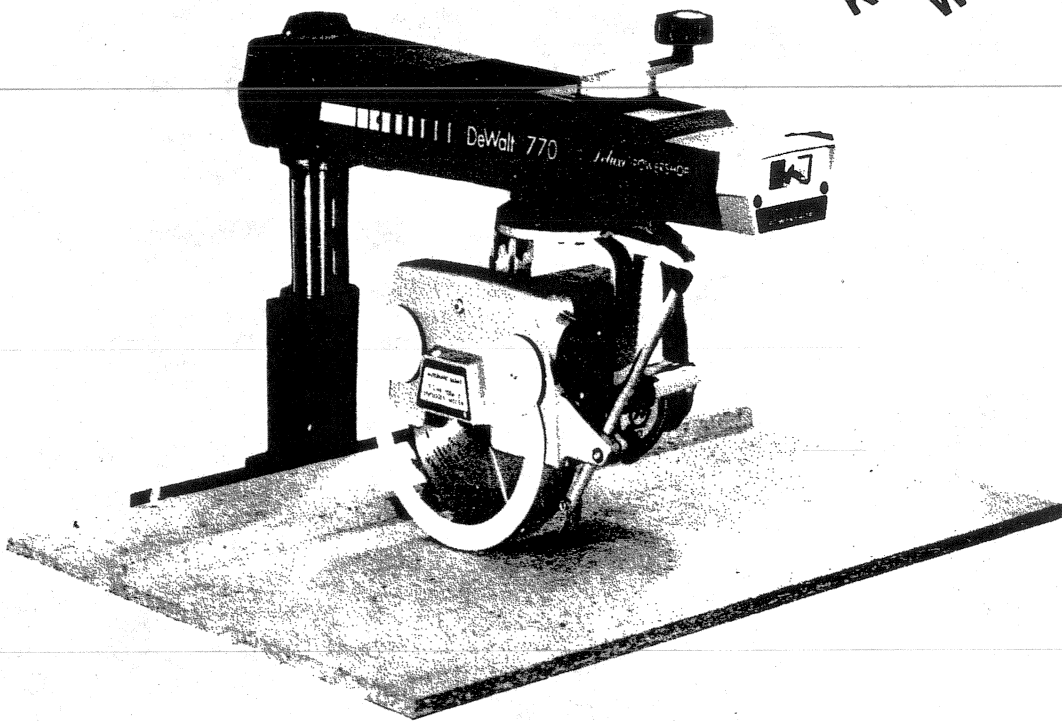

DEWALT®

use & care manual

**KEEP THIS BOOKLET
WITH THE SAW**



**WARNING: FOR YOUR OWN SAFETY, READ THIS MANUAL BEFORE OPERATING TOOL.
REVIEW SAFETY RULES AND OPERATING INSTRUCTIONS FREQUENTLY.**

This booklet is provided for your convenience in the use and care of your new DeWalt Saw. These instructions include operation, usage, precautions, preventive maintenance, maintenance and other pertinent data to assist you in assuring long life and dependable service from your saw.

7730, 7740, 7770 & 7779

10" RADIAL ARM SAW

Cat. Nos. 7730/3411, 7740/3421, 7770/3427
& 7779

780

12" RADIAL ARM SAW

Cat. No. 7780

INDEX

Unpacking, Setup, and Specifications	2-3
Electrical Connection and Grounding	3-4
Rules for Safer, Operation and Maintenance	4
Machine Controls	5
Alignment	6-12
Operating Instructions	13-16
Troubleshooting Guides.	17, 18, & 21
Accessories	19-20

Specifications	7730	7740	7770	7779
Motor	120V, 1 ph 2 HP	120V, 1 ph 2 HP	120/208-240V, 1 ph 2 1/2 HP	120/208-240V, 1 ph 2 1/2 HP
Motor Rating Develops	3450	3450	3450	3450
Full Load Speed-60 cy. AC				
Blade Guards (Upper and lower)	254 mm (10")	254 mm (10")	254 mm (10")	254 mm (10")
Standard Blade	254 mm (10")	254 mm (10")	254 mm (10")	254 mm (10")
Arbor Size	15.9 x 38.1 mm (5/8"x1 1/4") long	15.9 x 38.1 mm (5/8"x1 1/4") long	15.9 x 38.1 mm (5/8"x1 1/4") long	15.9 x 38.1 mm (5/8"x1 1/4") long
Maximum Depth of Cut	76.2 mm (3")	76.2 mm (3")	76.2 mm (3")	76.2 mm (3")
Maximum Depth of Cut at 45° Bevel	54 mm (2-1/8")	54 mm (2-1/8")	54 mm (2-1/8")	54 mm (2-1/8")
Cross Cut Capacity—1" stock	330.2 mm (13")	330.2 mm (13")	368.3 mm (14 1/2")	368.3 mm (14 1/2")
Spindle Dado Cap.—Width	20.6 mm (13/16")	20.6 mm (13/16")	20.6 mm (13/16")	20.6 mm (13/16")
Ripping Capacity—Width	627.1 mm (24-11/16")	627.1 mm (24-11/16")		627.1 mm (24-11/16")
Net weight	57.6 kg (127 lb.)	58.5 kg (129 lb.)	62.6 kg (134 lb.)	62.6 kg (134 lb.)

UNPACKING AND SET-UP INSTRUCTIONS

. . . you can easily set up your DeWalt Radial Saw, America's most popular power tool. Handling is minimized because every machine is assembled and job-tested at the factory, then partially knocked down for shipment to you. The only tools required are the wrenches furnished with the machine and screwdrivers from your tool box.

So that your new Radial Saw may be placed in operation just as soon as assembled, all electrical connections have been made at the factory to operate on 120 V single phase power supply. Models 7770, 7779 and 7780 have motors which can be reconnected for 240 volt operation. See Parts Bulletin.

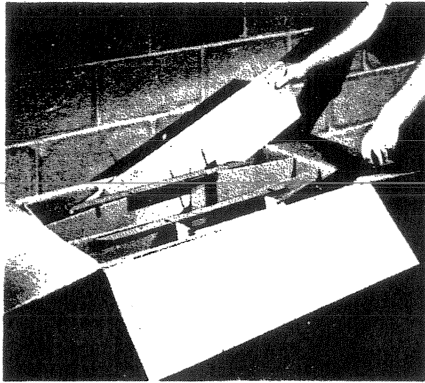

1. Remove table boards, metal cleats and legs, if provided, from carton.

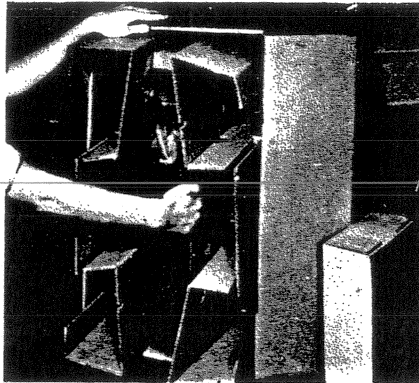

2. Remove guard box, tip carton on end and remove machine. Set machine upright.

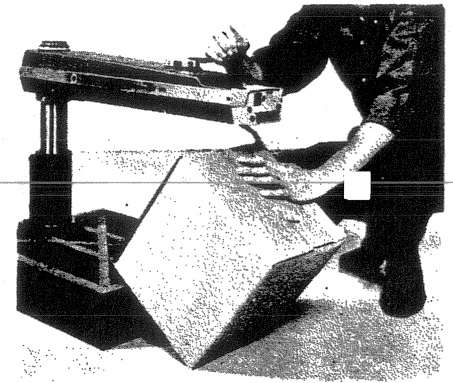

3. Raise arm assembly to free carton containing motor by turning elevating handle counter-clockwise. Remove motor from box. Unpack guard box and hardware bag.

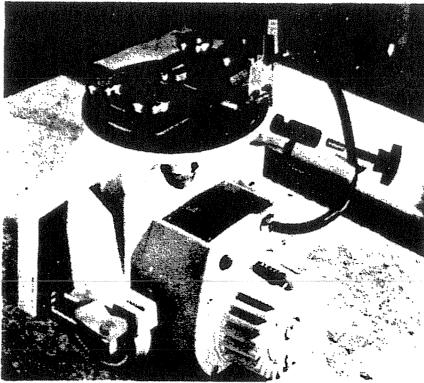

4. Insert slug and short threaded knob into Rip Lock and install into Roller Head as shown.

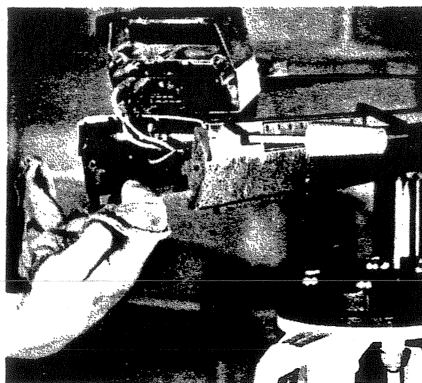

5. Remove two screws from arm end-cap, wipe arm tracks with clean cloth.

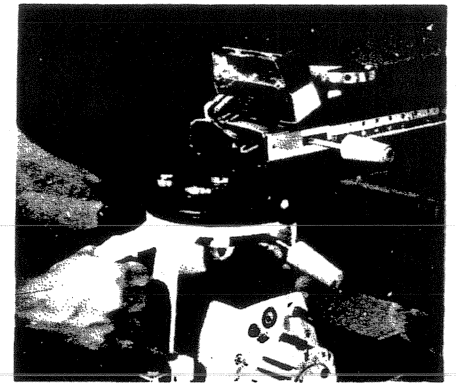

6. Carefully slide the motor assembly into the arm. Replace the endcap and tighten screws securely.

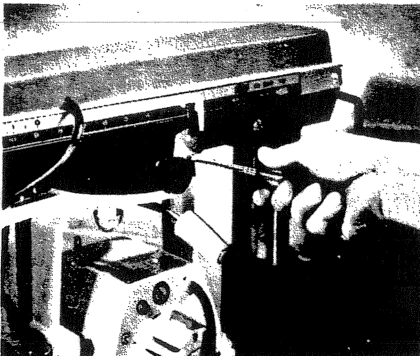

7. Install rip pointers with #6-32 x 1/4" long screws provided. Adjust both pointers to upright position and tighten screws.

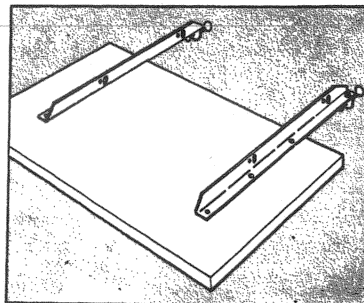

8. Assemble cleats on fixed board with the six (6) screws provided in the hardware bag. DO NOT TIGHTEN SCREWS ALL THE WAY DOWN. Insert the 5/16-18 x 1/4 hex head screw & (2) 5/16-18 thin hex nuts from hardware bag into table frame. (See picture page 9).

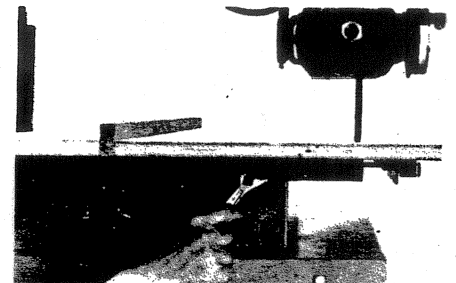

9. Insert 4 square bolts from inside of frame through table cleats. Attach flat washers, lockwashers and nuts and tighten finger tight. Then tighten the 10 screws securely.

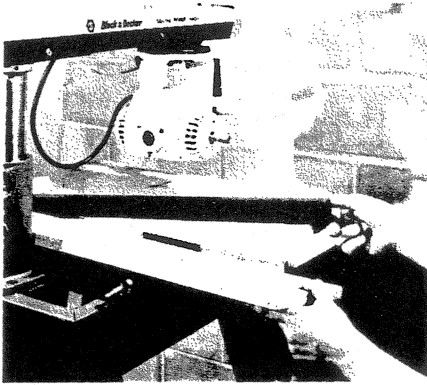

10. Assemble guide fence and spacer boards, thread thumb screw into bracket. Insert bracket into the slot provided in rear of cleats. Hold the eyelet in place and turn the thumb screw until it "pops" into place.

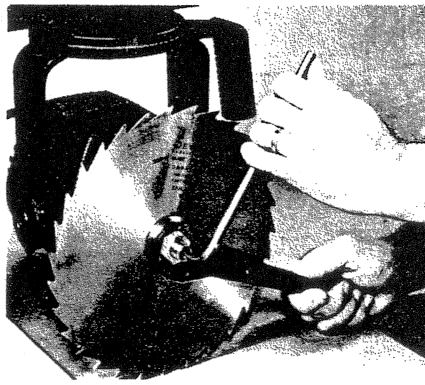

11. Place saw blade (with direction arrow as shown) between collars (recessed side against blade). Tighten arbor nut securely with both wrenches (left-hand threads).

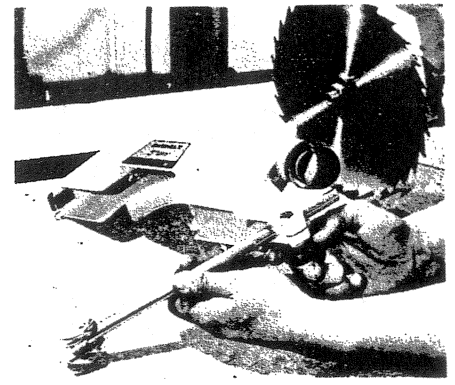

12. Assemble anti-kickback, locking knob, dust spout and lower guard except front inner retainer and inner ring per the Parts List diagram.

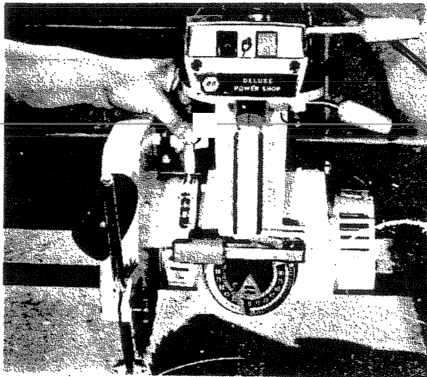

13. Place guard over blade tilting guard slightly to clear the arbor shaft. Seat guard on motor so that the guard rides in the circular slot in the motor and the motor stud goes through the hole in the guard. Secure with the wingnut. Place the inner ring under the motor and hook it over the rear retainer and the front boss. Install the front inside retainer with the thumbscrew and tighten securely. Note that this step must be repeated in reverse order to gain access to the blade for removing it. Place the key in the endcap but do not press the ON button. Your machine has been partially adjusted and aligned at the factory; before operating the saw perform the adjustments and alignments marked with an asterisk (*).

CAUTION

CAUTION

FOR PURPOSES OF CLARITY THE LOWER GUARD HAS BEEN OMITTED FROM THE PHOTOGRAPHS INSIDE THIS MANUAL. HOWEVER, ALL CUTS MUST BE MADE WITH BOTH THE UPPER & LOWER GUARDS IN PLACE.

ACCESSORIES

Recommended Blades and Accessories for your Radial Arm Saw are stocked by your B&D Dealer. These accessories are listed and described in the B&D DeWalt Catalog and on pages 19 and 20. CAUTION—The use of any other accessory might be hazardous.

1. Securely fasten the table frame to the Leg Stand or a sturdy work bench using the holes provided. Use sturdy outrigger supports if any table extensions are attached to the saw.
2. Shim under front legs tilting the saw backwards to prevent forward creeping of the carriage.
3. Read, understand and always practice the cautions and operating instructions contained within this manual.

ELECTRICAL CONNECTIONS AND GROUNDING

This tool should be grounded while in use to protect the operator from electric shock.

We recommend that you **NEVER** disassemble the tool or try to do any rewiring in the electrical system. Any such repairs should be performed only by B&D Service Centers or other qualified service organizations. Should you be determined to make a repair yourself, remember that the green colored wire is the "grounding" wire. Never connect this green wire to a "live" terminal.

1. **Cord-Connected Tools:** In the event of a malfunction or breakdown, grounding provides a path of least resistance for electric current to reduce the risk of electric shock. This tool is equipped with an electric cord having an equipment-grounding conductor and a grounding plug. The plug must be plugged into a matching outlet that is properly installed and grounded in accordance with all local codes and ordinances. Do not modify the plug provided — if it will not fit the outlet, have the proper outlet installed by a qualified electrician. Improper connection of the equipment-grounding conductor can result in a risk of electric shock. The conductor with insulation having an outer surface that is green with or without yellow stripes is the equipment-grounding conductor. If repair or replacement of the electric cord or plug is necessary, do not connect the equipment-grounding conductor to a live ter-

minal. Check with a qualified electrician or serviceman if the grounding instructions are not completely understood, or if in doubt as to whether the tool is properly grounded. Use only 3-wire extension cords that have 3-prong grounding plugs and 3-pole receptacles that accept the tool's plug. Repair or replace damaged or worn cord immediately.

1A. Grounded, cord-connected tools intended for use on a supply circuit having a nominal rating less than 150 volts. This tool is intended for use on a circuit that has an outlet that looks like the one illustrated in Sketch A. The tool has a grounding plug that looks like the plug illustrated in Sketch A. A temporary adapter, which looks like the adapter illustrated in Sketches B and C, may be used to connect this plug to a 2-pole receptacle as shown in Sketch B if a properly grounded outlet is not available. The temporary adapter should be used only until a properly grounded outlet can be installed by a qualified electrician. The green-colored rigid ear, lug, etc. extending from the adapter must be connected to a permanent ground such as a properly grounded outlet box. Adapter shown in Sketches B and C is Not for Use in Canada.

1B. Grounded, cord-connected tools intended for use on a supply circuit having a nominal rating between 150-250 volts, inclusive: This tool is intended for use on a circuit that has an outlet that looks like the one illustrated in Sketch D. The tool has a grounding plug that looks like the plug illustrated in Sketch D. Make sure the tool is con-

(Con't on p. 4)

ELECTRICAL CONNECTIONS AND GROUNDING (Con't from p. 3)

ected to an outlet having the same configuration as the plug. No adapter is available or should be used with this tool. If the tool must be reconnected for use on a different type of electric circuit, the reconnection should be made by qualified service personnel; and after reconnection, the tool should comply with all local codes and ordinances.

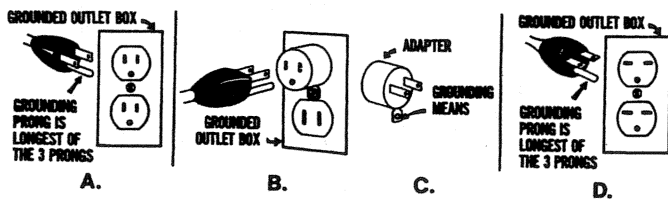

The use of a separate 15 ampere circuit is recommended for either 120 or 240 Volt operation.

RULES FOR SAFER OPERATION OF STATIONARY POWER TOOLS

1. **KEEP GUARDS IN PLACE** and in working order.
2. **REMOVE ADJUSTING KEYS AND WRENCHES.** Form habit of checking to see that keys and adjusting wrenches are removed from tool before turning it on.
3. **KEEP WORK AREA CLEAN.** Cluttered areas and benches invite accidents.
4. **DON'T USE IN DANGEROUS ENVIRONMENT.** Don't use power tools in damp or wet locations, or expose them to rain. Keep work area well lighted.
5. **KEEP CHILDREN AWAY.** All visitors should be kept a safe distance from work area.
6. **MAKE WORKSHOP KID PROOF** with padlocks, master switches, or by removing starter keys.
7. **DON'T FORCE TOOL.** It will do the job better and be safer at the rate for which it was designed.
8. **USE RIGHT TOOL.** Don't force tool or attachment to do a job for which it was not designed.
9. **WEAR PROPER APPAREL.** No loose clothing, gloves, neckties, rings, bracelets, or other jewelry to get caught in moving parts. Non-slip footwear is recommended. Wear protective hair covering to contain long hair.
10. **ALWAYS USE SAFETY GLASSES.** Also use face or dust mask if cutting operation is dusty. Everyday eyeglasses only have impact resistant lenses, they are NOT safety glasses.
11. **SECURE WORK.** Use clamps or vise to hold work when practical. It's safer than using your hand and it frees both hands to operate tool.
12. **DON'T OVERREACH.** Keep proper footing and balance at all times.
13. **MAINTAIN TOOLS WITH CARE.** Keep tools sharp and clean for best and safest performance. Follow instructions for lubricating and changing accessories.
14. **DISCONNECT TOOLS** before servicing; when changing accessories such as blades, bits, cutters, etc.
15. **REDUCE THE RISK OF UNINTENTIONAL STARTING.** Make sure switch is in off position before plugging in.
16. **USE RECOMMENDED ACCESSORIES.** Consult the owner's manual for recommended accessories. The use of improper accessories may cause risk of injury to persons. Use of blades with knock out inserts at the arbor hole may cause injury.
17. **NEVER STAND ON TOOL.** Serious injury could occur if the tool is tipped or if the cutting tool is unintentionally contacted.
18. **CHECK DAMAGED PARTS.** Before further use of the tool, a guard or other part that is damaged should be carefully checked to determine that it will operate properly and perform its intended function—check for alignment of moving parts, binding of moving parts, breakage of parts, mounting, and any other conditions that may affect its operation. A guard or other part that is damaged should be properly repaired or replaced.
19. **DIRECTION OF FEED.** Feed work into a blade or cutter against the direction of rotation of the blade or cutter only.
20. **NEVER LEAVE TOOL RUNNING UNATTENDED. TURN POWER OFF.** Don't leave tool until it comes to a complete stop.
21. **ONE OPERATOR ONLY.** The same person who pulls the saw should position the work.

MAINTENANCE AND OPERATION

1. **DO—Protect line** with at least a 15 ampere time delay fuse.
2. **DO—Be sure blade rotates clockwise** when facing arbor.
3. **DO—Be sure all clamp handles and thumb screws are tight** before starting any operation. Push handles back to tighten. Pull to loosen.
4. **DO—Be sure blade and arbor collars are clean and recessed side of collars are against blade.** Tighten arbor nut securely, using both wrenches provided. See Rule 16.
5. **DO—Keep saw blade sharp and properly set.**
6. **DO—Use anti-kickback attachment on guard.**
7. **DO—Keep arm tracks and bearing surfaces clean and dry.** Periodic cleaning with dry cleaner is recommended.
8. **DO—Periodically recheck alignment.**
9. **DO—Remove blade but not arbor collars and nut when using rear shaft.** Tighten nut securely.
10. **DO—Keep motor air slots clean and free of chips.**
11. **DO—Remove switch key and store in a safe place** to prevent unauthorized operation.
12. **DO—Use lower guard at all times.**
13. **DO—Return carriage to full rear** after each operation. A return reel is available.
1. **DON'T—Attempt to operate on anything but designated voltage.**
2. **DON'T—Operate unless all clamp handles are tight.**
3. **DON'T—Use blades of larger diameter than recommended.**
4. **DON'T—Remove anti-kickback from guard.** Adjust it to just clear the workpiece when crosscutting.
5. **DON'T—Rip from wrong direction—observe caution tag on guard.**
6. **DON'T—Oil or grease arm tracks or motor.**
7. **DON'T—Wedge anything against fan to hold motor shaft.**
8. **DON'T—Subject table top to variable humidity conditions** (keep away from dampness.)
9. **DON'T—Force cutting action.** Stalling or partial stalling of motor can cause major damage to motor winding.
10. **DON'T—Remove saw blade guard when boring.**
11. **DON'T—Remove arbor collars and nut when using rear shaft.** Tighten nut securely.
12. **DON'T—Remove ground prong from plug.** Never operate saw unless it is properly grounded.
13. **DON'T—Remove small scraps from table with fingers.**

The lower blade guard covers the side of the teeth when the blade is behind the fence. **READ THE FOLLOWING PRECAUTIONS.**

CAUTIONS TO FOLLOW WHEN USING LOWER GUARD:

1. The lower blade guard will provide additional protection from contact with the side of the blade—**BUT NOT FROM CONTACT WITH THE FRONT OR REAR OF THE BLADE.**
When the lower guard touches the fence or material being cut, it will rise up over the material—thus exposing the blade teeth. Be careful, keep your hands out of the line of cut!
2. Lower blade guards may become caught in prior kerfs in the fence or table. Replace guide fence frequently.
3. Short cut-off pieces of wood may become caught between the lower guard and the blade. If this happens shut off power; wait until blade stops before removal of piece.
4. The lower blade guards effectiveness is limited in bevel operations. It may have to be raised out of the way when setting bevel angle to prevent bending. **BE SURE THAT POWER IS OFF AND BLADE IS COMPLETELY STOPPED BEFORE MAKING ANY ADJUSTMENT.**
5. Catching the lower guard in saw kerfs when changing the saw set-up can be avoided by elevating the saw until the bottom of the guard clears the fence.
6. When ripping narrow strips, the lower guard may have to be raised to rest on top of the fence. Be sure to use a pusher stick to feed the work.
7. Do not use the lower guard with any accessory other than the correct size saw blade.
8. To summarize, when in doubt about whether to use the lower guard and when practical, make a "dry run" with power off to determine if it is a help or hindrance.

MOTOR OVERLOAD PROTECTION

Your Saw Motor is equipped with a manual-reset type overload protector. If the protector "trips" and stops the motor, take the following steps:

1. Press the saw "OFF" switch button and allow the motor to cool.
2. After motor has cooled, the overload protector may be reset by firmly pressing the red reset button. If you do not hear an audible "click", the motor must be allowed to cool further before attempting the reset.
3. After the reset is accomplished, the saw may be started by pushing the "ON" button.

RADIAL-ARM MACHINE CONTROLS. The versatility of the radial-arm machine is due, in part, to its controls, and these are the keys to its successful operation. Learn to use them by adjusting the machine for all operations before actually starting to operate it. All controls, as well as the major parts of the radial-arm machine, are shown and identified here.

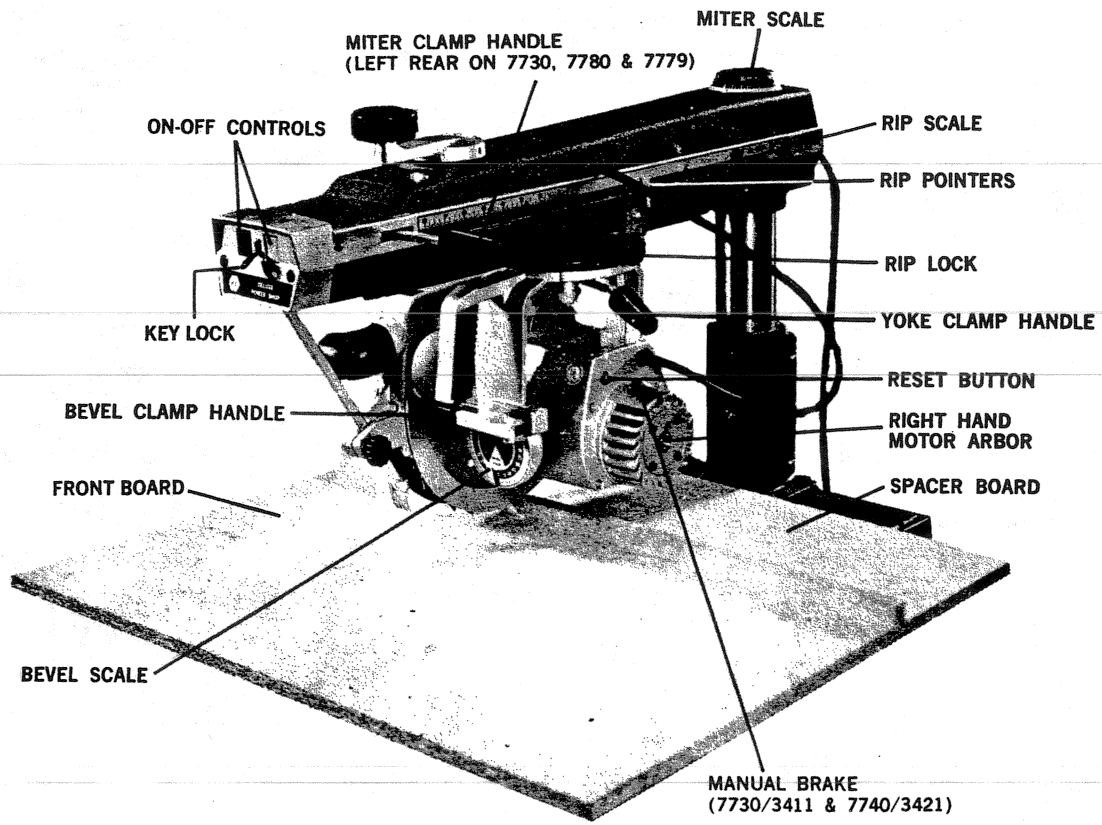
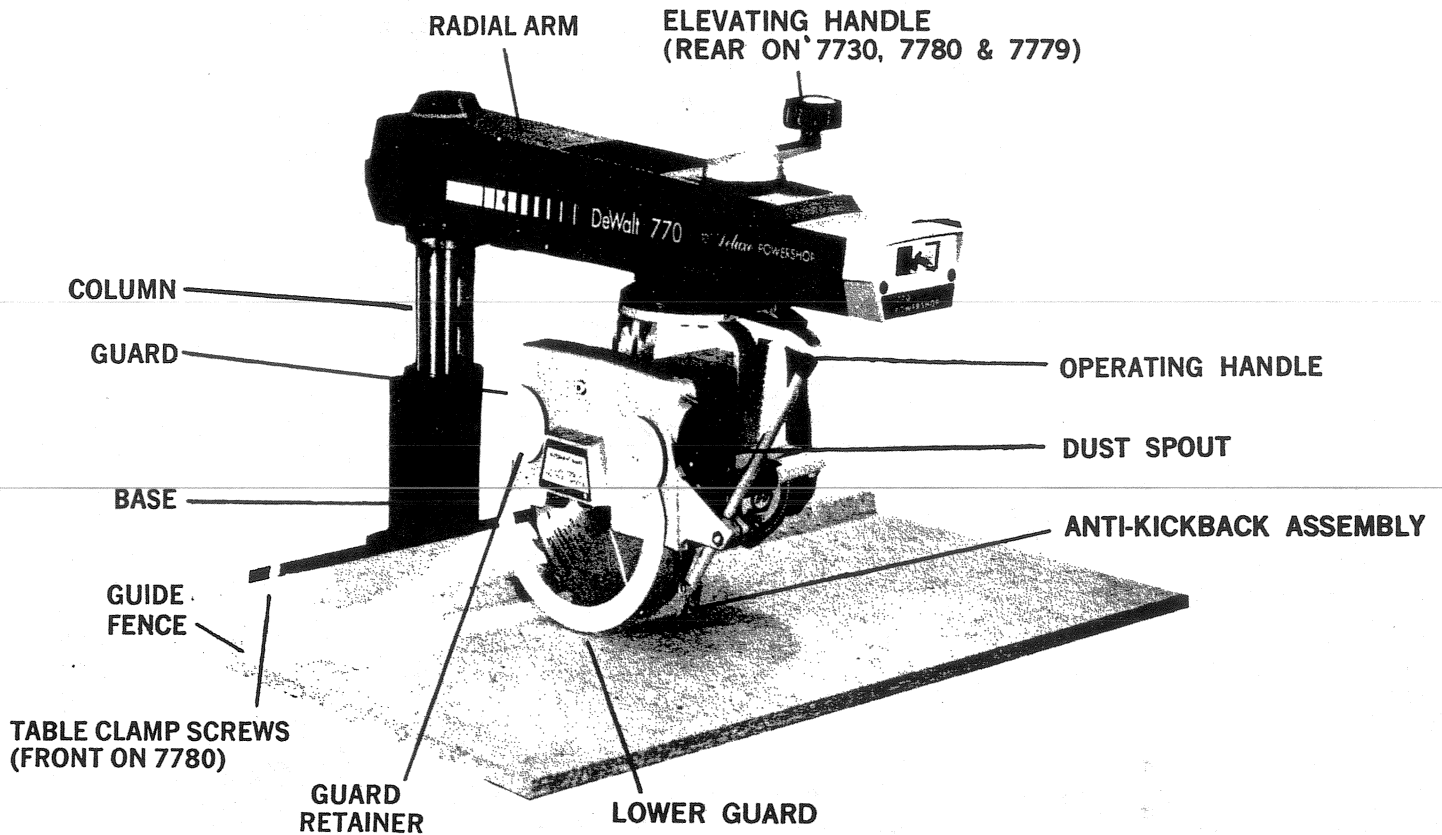

ALIGNMENT

MAKE CERTAIN SAW IS NOT CONNECTED TO POWER SOURCE. NOW BEFORE GOING ANY FARTHER TAKE TIME OUT TO READ THE FOLLOWING IMPORTANT INSTRUCTIONS. THE ALIGNMENT OF YOUR NEW SAW IS MOST IMPORTANT NOT ONLY FOR MAKING ACCURATE CUTS, BUT ALSO FOR SAFER OPERATION. THE TIME SPENT HERE WILL ADD CONSIDERABLY TO YOUR OVERALL ENJOYMENT OF THIS FINE PRODUCT. NOTE: SECURE TABLE FRAME OF UNIT TO A STURDY WORK BENCH, APPROPRIATE TABLE, OR LEG STAND, WITH SCREWS OR BOLTS BEFORE MAKING ALIGNMENTS OR OPERATING. THESE UNITS WILL FIT A NO. R-1201 LEG STAND.

Your saw was completely inspected and tested but only partially aligned at the factory. The alignments preceded by an asterisk (*) are to be made by you prior to use.

YOKE CLAMP HANDLE ADJUSTMENT

The purpose of this handle is to provide a friction lock between the upper face of the yoke and the bottom face of the rollerhead. It should also eliminate any play between these two parts. In operating position the yoke clamp handle is pushed back from the hand grip of the yoke. If, at any time, it is possible to move this handle so that it strikes the rear leg of the yoke, it is not in proper adjustment. Its proper position for machine operation is approximately 90° or less to the hand grip of the yoke.

To readjust:

- Pull yoke clamp handle forward to release friction locking action.
- Insert screw driver between the yoke and the notched clamp adjustor. Flex the adjustor downward just enough to pass over the lug stop on the yoke.
- Rotate clamp adjustor as necessary (to loosen, clockwise; to tighten, counter-clockwise). Be sure the notch in the adjustor is positioned properly over the yoke lug stop at final setting.

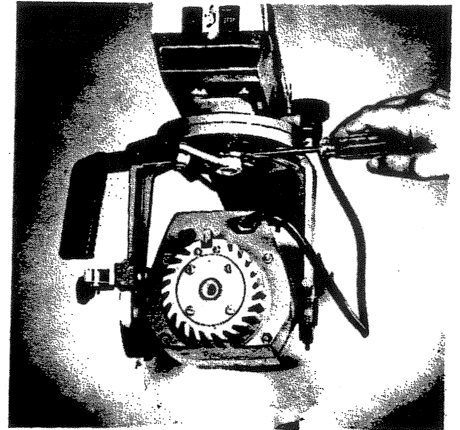

NOTE: † If difficulty is encountered in making the above adjustments we suggest that you remove the arm end cap and slide the entire motor, yoke and rollerhead assemblies from the arm. This will provide access to the king bolt and by turning this with a large screwdriver it will assist in the above adjustment procedure.

† Newer saws have a king bolt with a hex hole in the threaded end which is easily accessible without removing any part from saw. Adjustment can be made with the 1/4 hex wrench which is furnished with the saw.

ADJUSTING BEVEL CLAMP HANDLE

The purpose of the bevel clamp is to hold the motor at any angle. This is accomplished by the cam action of the clamp pulling the clamp pad against the dial plate.

To adjust:

Loosen set screw (A), tighten clamp bolt (B), then retighten set screw.

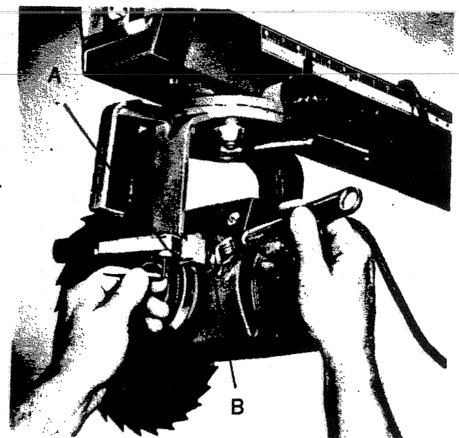

ADJUSTING ROLLERHEAD BEARINGS TO ARM TRACKS

The rollerhead is suspended by four special tolerance, greased-packed, double shield ball bearings. These bearings are mounted on two straight bearing shafts and two eccentric bearing shafts. In proper adjustment the top and bottom radii of all four bearings should be in contact with the arm tracks for their entire length and head should roll freely but with some resistance. Excessive bearing pressure will cause difficult operation and rapid wear. Too little pressure will cause loss of accuracy and the saw will try to feed itself into the material being crosscut. Proper adjustment will require a force of 4 to 6 pounds to move the rollerhead along the arm at a constant speed. The front and rear bearings should be adjusted to contribute equally to this force. NOTE: the end cap was removed for clarity and it need not be removed for this adjustment.

- Wipe tracks with a clean dry lint-free cloth.
- Bring motor, yoke, and rollerhead assemblies to the end of arm.
- Set in "out rip" position.
- Loosen hex nuts on left side, front and rear.
- Insert $\frac{1}{8}$ " Allen wrench in recess at bottom of shafts and turn bearing shaft until the bearing is snugly against the track. Repeat for the second bearing. Check the force required to move the rollerhead. Readjust as required.
- Tighten the hex lock nuts while holding each bearing shaft in its adjusted position.

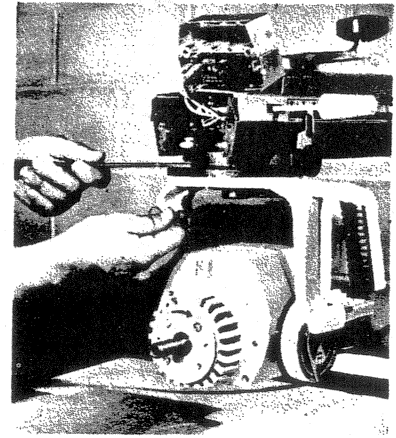

ARM TO COLUMN

Prior to readjusting the arm clamp cam check adjustment of the arm to column. With the arm clamp released there should be no vertical play in the arm, and the arm should fit snugly on the column.

To adjust:

- Loosen two jam nuts (A) in slot at rear of arm, turning them clockwise.
- Adjust bolts (B) for proper fit and re-tighten jam nuts (A).

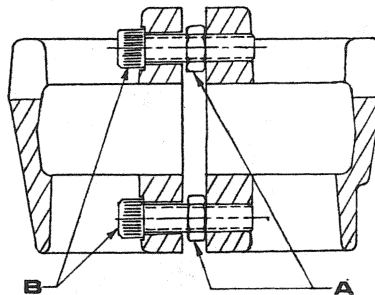

Cross section of back of arm with shroud removed

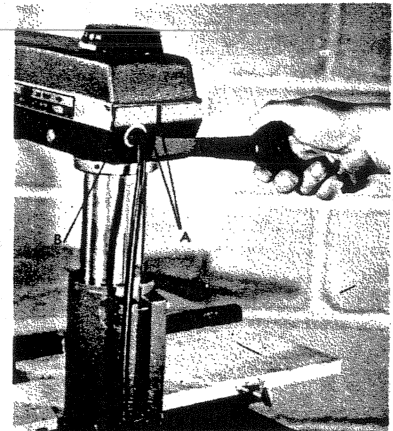

REMOVING SHROUD

To make adjustments in the arm it is necessary to remove the arm cover, as follows:

- Remove elevating handle. Handle is held on by a set screw.
- Remove miter scale by loosening and removing screws.
- Remove four screws holding plates on each side of arm.
- Remove plates and arm cover.

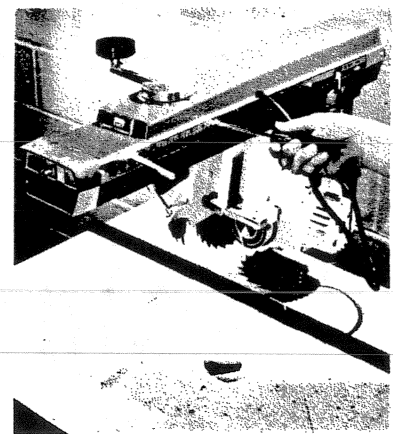
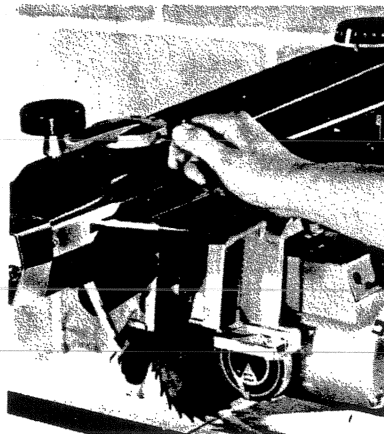

ADJUSTING ARM CLAMP (7740 & 7770 ONLY)

The arm clamp handle operates a cam that clamps and releases the arm, and lifts the miter latch from the 0° and 45° slots.

To adjust:

- Loosen set screw (A) on clamp bolt (B) in clamp cam pivot pin (C).
- To tighten clamp turn clamp bolt clockwise. (Very little adjustment should be made prior to trying the clamp.)
- Retighten set screw (A).

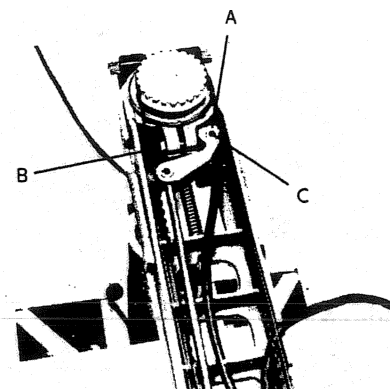

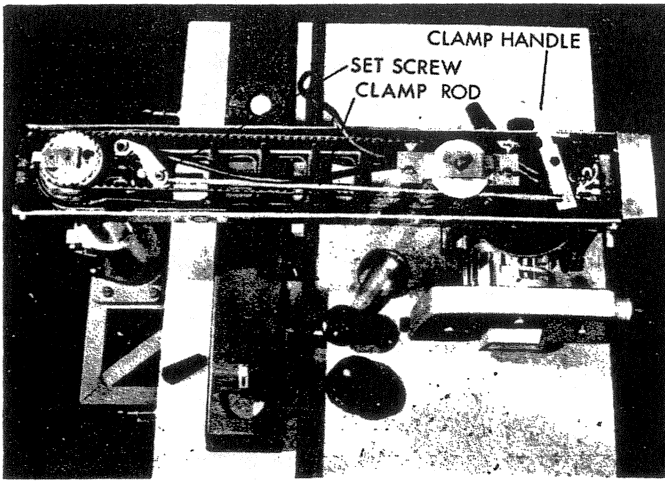

MITER CLAMP HANDLE POSITION

Position of the clamp handle may need adjusting after the clamp cam has been adjusted.

To adjust:

- (a) Loosen set screw in pivot pin on the clamp rod.
- (b) Turn the clamp rod so that the handle does not contact casting when clamped or released. Re-tighten set screw.

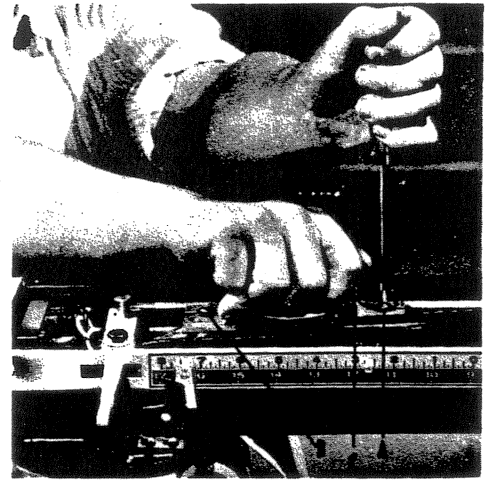

ADJUSTING BELT TENSION

It is necessary to remove the arm cover to adjust the timing belt tension.

To adjust:

- (a) Loosen two screws marked (A) and (B).
- (b) Pull and hold sprocket bracket (C) to apply belt tension.
- (c) Tighten screws (A) and (B) securely.

Note that excessively tight base adjustment may cause the belt to slip or jump from its pulley.

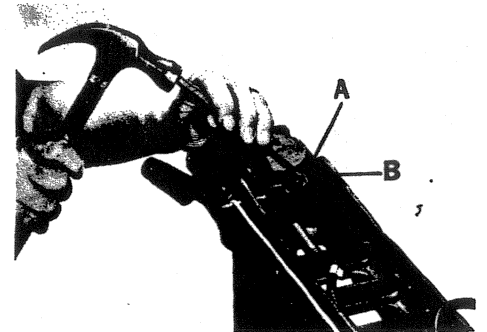
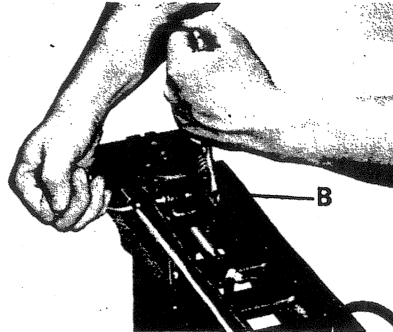
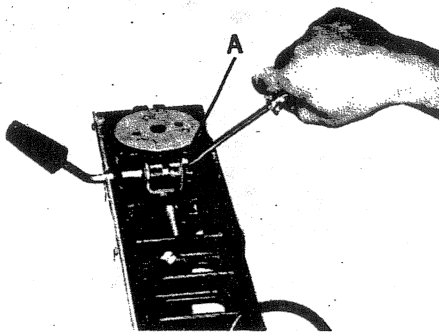

ARM CLAMP ADJUSTMENT (7730, 7780 & 7779 ONLY)

The arm clamp handle clamps and unclamps the arm, and operates a lever that disengages the miter latch. To adjust:

- (a) Straighten wrench clip (A) by prying with a screw driver.
- (b) Tighten arm clamp by turning clamp nut (B) counter-clockwise.
- (c) Reband the wrench clip (A) onto a flat on the clamp nut (B) securing the nut in position.

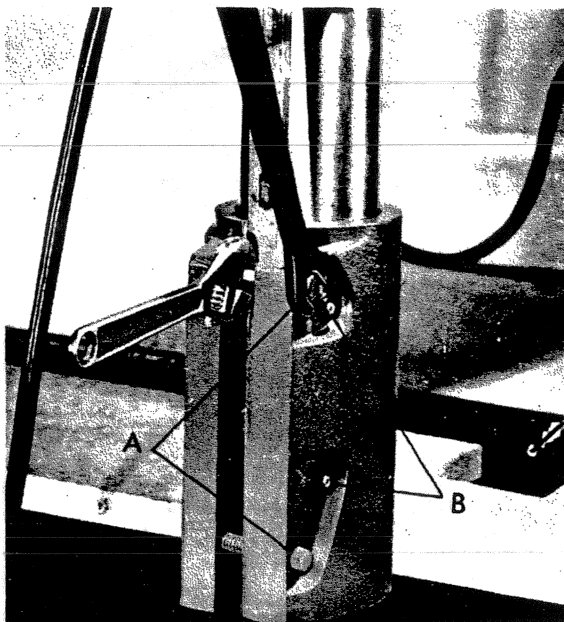

ADJUSTING BASE TO COLUMN

If noticeable play exists between the base and the column or if the saw is hard to elevate, then the base requires adjustment.

To adjust: (Face rear of machine)

- (a) Loosen locknuts and brass set screws (B). Loosen jam nuts and clamp bolts (A). Adjust lower bolt first.
- (b) Elevate and lower the arm. If the column binds and elevation is difficult, tighten the jam nuts (A) against the right side of the slot until there is no play but elevation is moderately easy. Then tighten bolts (A) holding the jam nuts in place.
- (c) If the column is loose in the base, tighten bolts (A) until the proper adjustment is achieved. Holding each bolt tighten its jam nut against the left side of the slot.
- (d) Push the arm to the right. Bring the setscrews (B) lightly against the column key to remove all rotary play. Tighten their locknuts lightly. Caution: excessive torque on the setscrews or locknuts may cause setscrew damage.

*ADJUSTING TABLE TOP PARALLEL WITH ARM

The table top surface must be parallel with the horizontal plane of the arm tracks.

To align proceed as follows:

- (a) Remove the guard, the blade and the washers from the motor.
- (b) Elevate the saw about 20 turns.
- (c) Release the bevel lock lever and pull the bevel locating pin.
- (d) Revolve the motor until the arbor is 90° to the table.
- (e) Release the miter lock and locator so you can move the arm to the right and left.
- (f) Lower the arm until the end of the arbor is just over the table.
- (g) Bend down so that your eye is even with the table top.
- (h) Move the arm to the right and left and push the roller head back and forth and notice if there is any change in the distance between the end of the arbor and top of the table.
- (i) If the clearance (distance) is the same over the entire surface the table is parallel to the arm.
- (j) If there is a difference in the clearance, adjust as follows.

Position the end of the arbor directly over the highest point on the table. Look under the table and you will notice four (4) locking nuts that hold the cleats to the frame. Now position the end of the arbor directly over the nearest locking nut to this high point. Lower the arbor until it touches the table. You may have to adjust one, two or three nuts to get the table parallel. Now move the arbor directly over another locking nut. Loosen the locking nut and push the table up until it touches the end of the arbor. *Tighten* the locking nut. If required, adjust the other locking nuts in the same manner.

A concave table top condition can be eliminated by proper adjustment of the jackscrew and locking nut assembly. Assemble 5/16-18x1¼ adjusting screw "A" and 5/16-18 nuts "B" and "C" from hardware bag as shown in Figure A.

Hold jackscrew "A" while turning pressure nut "B" clockwise (viewed from the top). After jackscrew contacts table and continues upward, center of table top will be lifted towards motor arbor. When the table top is parallel to the motor, lock the jackscrew by turning the locking nut "C" clockwise (viewed from the bottom) while holding jackscrew "A". Check table top for parallelism once more, then tighten the pressure & lock nuts "B" and "C" once more to assure locking jackscrew "A".

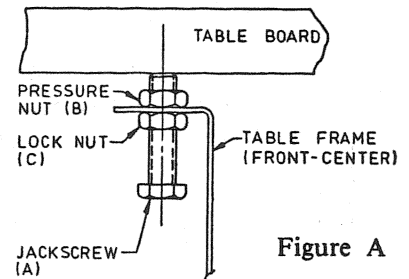
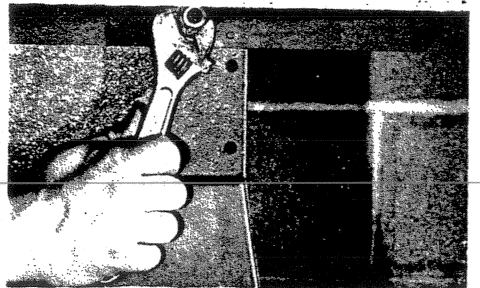
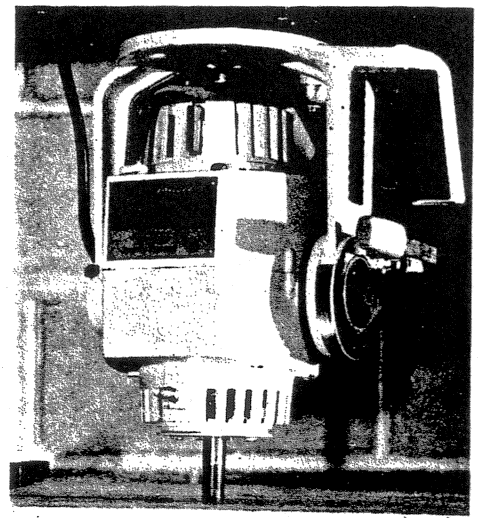

CHECK TABLE TOP AND GUIDE FENCE

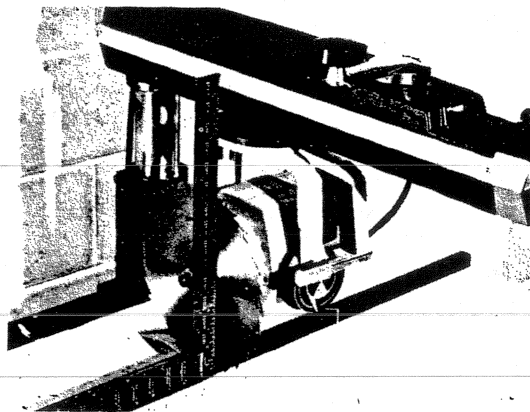
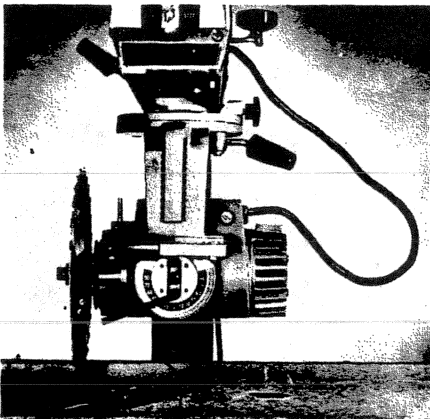

The table top assembly and guide strip are checked for straightness before leaving the factory. As all wood products must "breathe" and are affected by various humidity conditions, a slight change from factory conditions may sometimes be found. Straightness of top and Guide Strip, with Clamp Screws tight, should be checked with a square or straight edge. Correction can be made only by sanding. A slight variation from perfect straightness of table top will not normally affect the average woodworking requirements.

Do not use a level except as a straight edge. (This check is for straightness, not levelness with the floor.)

* ADJUSTING BLADE PERPENDICULAR TO WORK TOP

With the arm in cross-cut position, all latches engaged and all clamp handles locked place a steel square with one edge on the table top parallel to guide strip and the other edge against the flat of the saw blade (place in saw blade gullets and not against teeth because of tooth set). If blade is not flat against square, adjust as follows:

- (a) Remove bevel pointer by removing two screws.
- (b) Loosen two outside socket head screws.
- (c) Tilt motor until blade is flat against the square and again lock (very firmly) socket head screws. Replace bevel pointer.

NOTE: In some cases it will be found necessary to also loosen center cap screw in order to adjust motor.

* BEVEL SCALE

The bevel scale is located at the front of the motor. When the motor is positioned for vertical cutting the pointer should be at 0 on the scale. To adjust loosen the two screws, move the pointer to 0 and tighten.

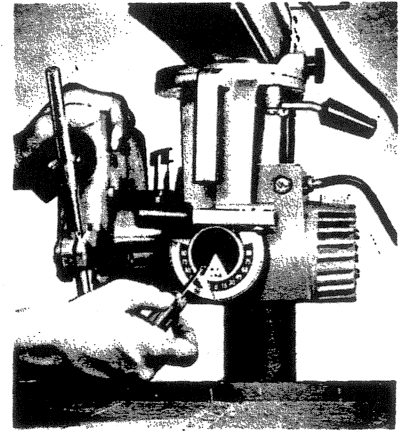

* ADJUSTING CROSS CUT TRAVEL WITH GUIDE FENCE

With the miter latch engaged and arm clamp handle locked, place a wide board (1" x 12" if available) against the guide strip. Cross-cut this board with a set tooth blade. Check cut with a steel square. If cut is not square, the arm is out of alignment with the guide fence.

To readjust:

- (a) Loosen arm clamp handle (B).
- (b) Loosen two set screws under the miter adjusting screws.
- (c) Lay steel square on table top with one edge against guide fence and the other edge at 0° cross-cut as shown in picture.
- (d) Move saw carriage and blade forward along steel square to determine which way arm must be adjusted.
- (e) If saw blade moves toward square as it comes forward, disengage miter latch. With screw driver loosen left adjusting screw and tighten right adjusting screw, re-engage miter latch. Check and repeat if necessary.
- (f) If saw blade moves away from square as it comes forward, disengage miter latch. Loosen right adjusting screw and tighten left adjusting screw, re-engage miter latch. Check and repeat if necessary.
- (g) When saw travel is parallel to square for entire length, lock adjustment screws in place by retightening set screws.

NOTE: Do not tighten adjusting screws enough to retard the operation of the miter latch.

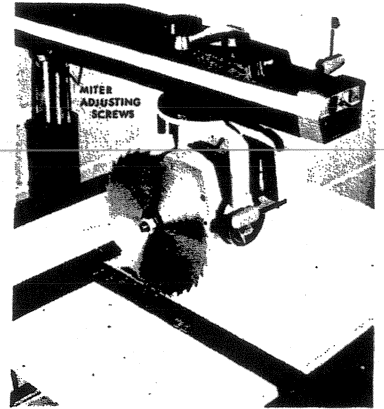

* MITER POINTER

The miter pointer is located at the top on the back of the arm. When the arm is positioned for straight cross-cut the pointer should be at 0° on the scale.

To adjust:

- (a) 7740 & 7770: loosen rear screw located on the top of the miter scale, rotate the scale to zero, retighten screw.
- (b) 7730, 7780 & 7779: loosen the screw holding the pointer, move the pointer to zero and retighten screw.

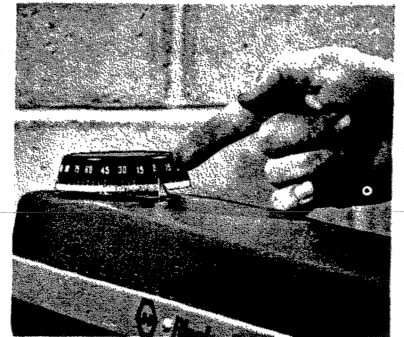

DIRECTIONS FOR REMOVING ARBOR NUT

1. Fit 5/16" wrench into front end of motor shaft.
(This is a holding wrench only.)
2. Fit large wrench on arbor nut as nearly parallel to first wrench as possible.
3. While holding Allen wrench stationary with left hand, use downward pressure of right hand on second wrench and nut will loosen. See Figure 11, page 3.

ADJUSTING CROSS-CUT TRAVEL PARALLEL TO ARM TRACKS (HEEL ADJUSTMENT)

Both the leading and trailing teeth of the saw blade should travel in the same plane parallel to the arm tracks. To check, place a board 4" x 1" or larger against the right side of the guide fence. With the machine in 0° cross-cut position and all locks and latches engaged, end trim this stock by allowing only the front teeth of the blade to clear the stock and the rear teeth remaining in the cut. Now remove the stock by sliding to the right before returning the cutting head to the back of the arm. Examine the cut edge of the stock. If blade marks of the rear teeth are prominent on the cut stock the rear teeth are not exactly following the front teeth and adjustment is necessary. (The arcs of the rear teeth start at the bottom front of the stock and travel up and back.) Repeat this same operation with the stock against the left side of the guide fence.

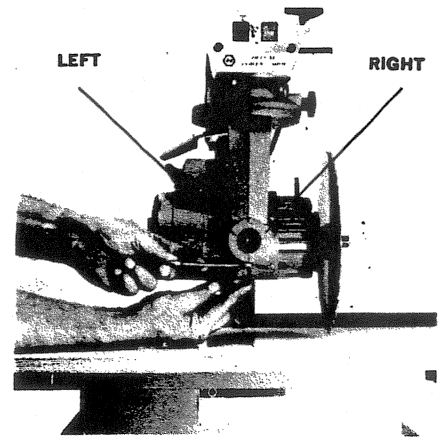

Saw swivelled 180° for clarity

To adjust when marks are on stock cut on right side:

- Disengage bevel clamp handle. Do not pull bevel pin.
- Loosen right and left lock nuts at rear of yoke.
- Loosen right set screw about 1/6 turn and tighten left set screw.
- Retighten lock nuts and bevel clamp handle.
- Recheck as above by cutting.

To adjust when marks are on stock cut on left side:

- Disengage bevel clamp handle. Do not pull bevel pin.
- Loosen right and left lock nuts.
- Loosen left set screw about 1/6 turn and tighten right set screw.
- Retighten lock nuts and bevel clamp handle.
- Recheck as above by cutting.

After left and right adjustments have been made, tilt the motor to 45° bevel cross-cut position and again make cuts on 2" x 4" stock as was done in cross-cut

position. If tooth marks again appear the motor is too high or low in the rear of the yoke.

To adjust when marks appear on bottom side of cut (left-hand piece of stock):

- Disengage bevel clamp handle. Do not pull bevel pin.
- Loosen all lock nuts.
- Loosen by equal amounts right and left set screws about 1/6 turn and tighten bottom set screw.
- Retighten lock nuts and bevel clamp handle and recheck as above by cutting.

To adjust when marks appear on upper side of cut:

- Disengage bevel clamp handle. Do not pull bevel pin.
- Loosen all lock nuts.
- Loosen bottom set screw about 1/6 turn and tighten right and left set screws.
- Retighten lock nuts and bevel clamp handle and recheck as above by cutting.

Now Go Back And Check Cross Cut Adjustments

*RIP SCALE

The rip scale is located on the right side of the radial arm. When the motor is positioned with motor arbor toward the column it is called "in rip" position, and material should be fed from right to left. When the motor arbor is positioned toward the operator it is called "out rip" and material is fed from left to right. When "in ripping" width dimensions are located on the top of the scale and when "out ripping" on the bottom of the scale by use of the reference pointers. The pointers are adjustable and must be readjusted only when gauge (thickness) of blade is changed.

To adjust:

To set the "in rip" and "out rip" pointers, first set the saw in an "out rip" position and then set the saw blade at a predetermined distance from the fence. After you have done this loosen the two screws holding the pointer. Adjust the "out rip" pointer equal to the distance between the saw blade and the fence, and tighten the screws. Then turn the saw to an "in rip" position and push the blade against the fence. Adjust the "in rip" pointer to zero (0) on the scale.

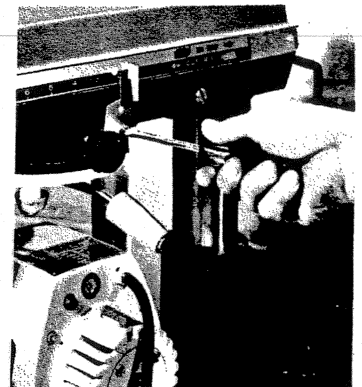

CUTTING KERF MARKS

OPTIONAL: Prior to cutting kerf marks you may elect to place a protective material over your table top. This material can easily be replaced as required without disturbing the saws alignment. Cut a piece of $\frac{1}{4}$ " plywood the same size as the front board and secure it to the front board with countersink $\frac{3}{4}$ " brads. Do not nail where the saw kerfs will be located. It is not necessary to cover the spacer or back boards.

After all your adjustments are made you should now cut into the table top the most common kerf marks. This will allow you to move the saw into different positions without changing the elevation. To do so proceed as follows:

- (a) Locate and lock the arm 90° to the fence. Locate the blade 90° to the table.
- (b) Draw the saw out to about the middle of the track and lower the blade until it just grazes the ply top.
- (c) Turn the saw on and push the roller head all the way back. This will cut the fence and lightly score the ply top.
- (d) Lower the arm (saw still running) $\frac{1}{4}$ turn. Pull the saw forward to the end of the arm with your *left hand*. This will cut a groove in the table top $1\frac{1}{32}$ " deep. Tighten Rip Lock. (Refer to figure 1)
- (e) With the saw still running and your left hand still on the handle release the yoke lock with your right hand and pull it with sufficient strength so the yoke clamp handle presses against the yoke locator pin bell pulling the yoke locator pin out of the hole in the roller head. You can now rotate the saw blade in a clockwise direction. Release the pressure on the bell and continue rotating the blade until the spring mounted yoke locator pin falls into the next hole. You have now cut in the table top a $\frac{1}{4}$ turn groove known as the swing line. The saw is now in the "in-rip" position. (Refer to figure 2) Loosen Rip Lock.
- (f) Once the $\frac{1}{4}$ turn cut is complete lock the yoke lock with your right hand and with the blade still revolving push the yoke back on the track until the blade reaches the fence. This will cut the rip through in the center of the table. Stop Motor. (Refer to fig. 3)
- (g) Return saw to position shown in figure 1. Lock Rip Lock and start motor. Using the yoke clamp handle, release the pressure on the bell and rotate saw counterclockwise, to the outtrip position. This cuts the swing line for outtripping. Loosen rip lock.
- (h) Lock the yoke lock (clamp handle), and with your right hand and blade still revolving, push the saw back until the new trough matches the trough cut in (f) Stop Motor.
- (i) Return saw to position shown in figure 1 and move to the rear position behind the fence.
- (k) Lock Rip Lock and start motor. With motor running release the miter handle with your right hand and move arm to the 45° right hand miter position. This will cut a trough for mitering. (Optional step) Repeat above for 45° left hand miter. Stop Motor.

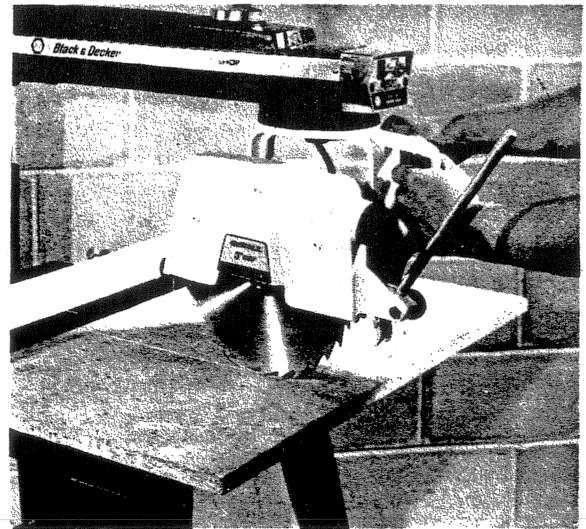

FIGURE 1

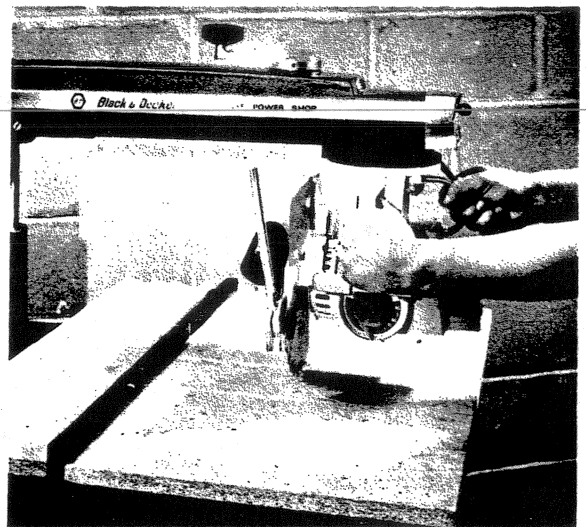

FIGURE 2

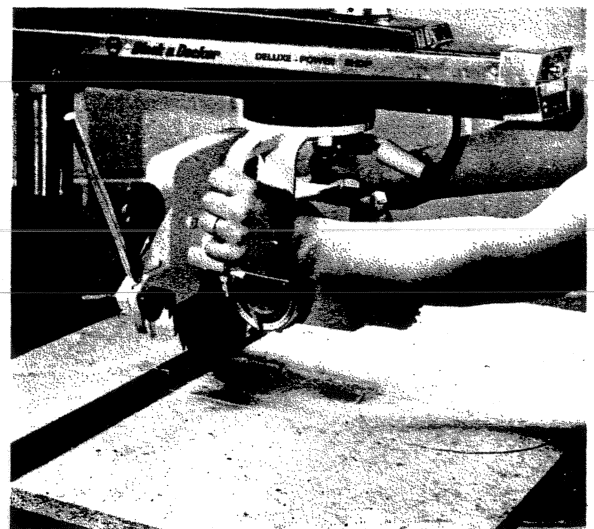

FIGURE 3

• OPERATING INSTRUCTIONS •

Observe and comply with the warning labels on the saw.

WARNING

FOR YOUR OWN SAFETY READ INSTRUCTION
MANUAL BEFORE OPERATING SAW

1. Wear eye protection.
2. Keep hands out of path of saw blade.
3. Return carriage to full rear position after each crosscut type of operation.
4. Know how to reduce risk of kickback.
5. Use pusher board for narrow work.
6. Do not perform any operation freehand.
7. Never reach around moving saw blade.
8. Shut off power before clearing a stall or jam.
9. Make no adjustments until tool has stopped.

DANGER

TO AVOID INJURY DO
NOT FEED MATERIAL
INTO CUTTING TOOL
FROM THIS END

Use common sense, think all operations through before starting, and be alert.

Review the "Rules For Safer Operation of Stationary Power Tools" and "Maintenance and Operation" sections. (See index)

Keep saw in good adjustment and alignment; use only sharp, free-cutting tools and accessories that were designed for your machine. These precautions will help reduce the possibility of jam-ups or kickbacks.

Never perform any operation "free hand" (i.e. supporting the workpiece by hand alone). The workpiece must always be solidly supported or guided by the fence or supporting jig or fixture to prevent any unexpected movement.

If the sawblade or cutter becomes stalled or lower guard becomes jammed - Turn off power immediately. Never attempt to free a jam up without first turning power off. Remove workpiece and re-check machine alignment. Adjust as necessary.

DANGER Coasting cutting tools can be dangerous - apply the brake immediately on manual braking units to stop the tool as soon as the switch is turned off.

The torque developed during manual or automatic braking may loosen the blade retaining nut, therefore the arbor nut should be checked periodically and tightened if necessary.

Never cycle the tool "on" and "off" rapidly, as forces can be produced which will loosen the arbor nut.

If the arbor nut should ever loosen, allow the blade to come to a complete stop and re-tighten the arbor nut securely, but not excessively, using both wrenches provided.

Read through and study the pictorial operating instructions which follow for further instructions before using your new DeWalt powershop.

Kickbacks can occur when the workpiece binds between the saw blade and the fence during a ripping type operation. Such action could cause the workpiece to be ejected from the machine and thrown violently back towards the operator.

Never stand, or permit someone else to stand in line with the work being ripped due to possible kickbacks.

The anti-kickback fingers must be kept sharp, free moving and correctly adjusted to insure proper operation.

Use extra care when ripping material that is twisted or bowed which can rock on the saw table and cause pinching or binding. Place the wood on the table in such a manner as to minimize rocking.

A pusher board should be used when ripping narrow work (i.e. less than 3 inches or so between the blade and fence). The pusher board should be made from clear, straight grained lumber as shown below.

It is easier to change the saw set-up and will prevent lower guard catching if work table is higher than rear table. 1/4" plywood and brads may be used to cover the front table.

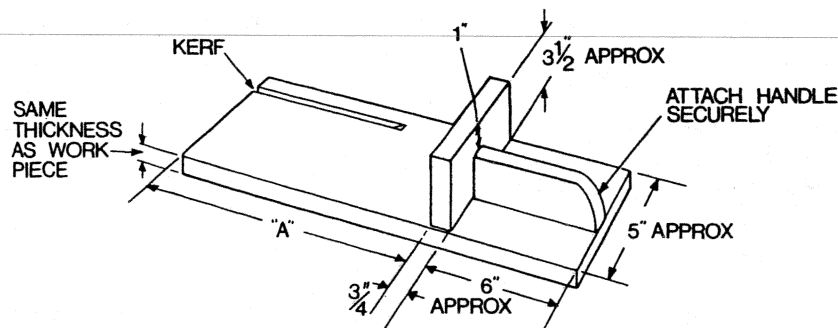

Dimension "A" must be such that the workpiece is fed completely past the blade but short enough to prevent the pusher board from passing under the anti-kickback device.

The pusher board should be pre-kerfed prior to use, for every new width of rip a new or re-worked pusher board must be used.

Do not rip workpieces shorter than 12" in length.

· OPERATING INSTRUCTIONS ·

CAUTION

FOR PURPOSES OF CLARITY THE LOWER GUARD HAS BEEN OMITTED FROM THE PHOTOGRAPHS INSIDE THIS MANUAL. HOWEVER, ALL CUTS MUST BE MADE WITH BOTH THE UPPER & LOWER GUARDS IN PLACE.

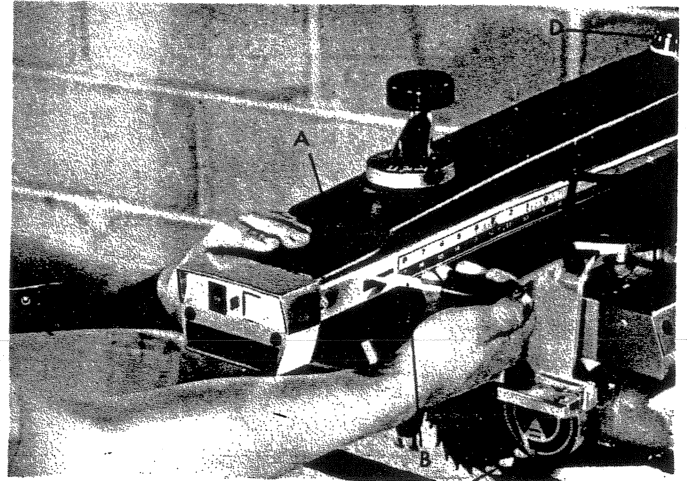
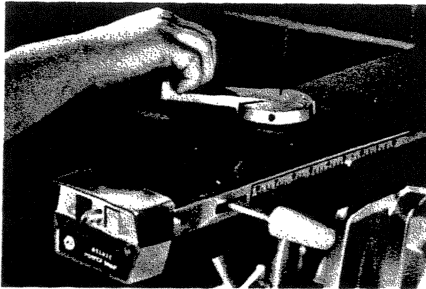

FIG. A

ARM ROTATES RIGHT OR LEFT FOR MITER CUTS

Pull clamp (B) then swing the arm (A) right or left to the desired angle. The calibrated miter scale (D) is at eye level and shows the precise angle you want. With the handle released, the miter latch will automatically locate 0° and 45° angle. After positioning arm (A) in the desired angle, push clamp (B) to lock the arm. NOTE: On Model 7730, 7780 & 7779 the clamp (B) is located at the left rear of the arm.

FIG. B



Elevation

Each full turn on the elevating handle (C) lifts or lowers the arm (A) exactly 1/8 inch.

FIG. C

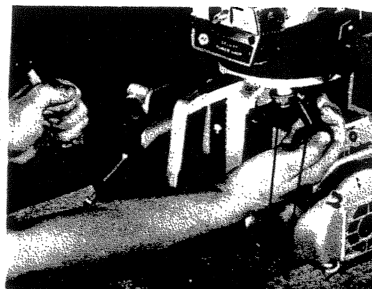

Saw Swivels 360° for Rip Cuts

Pull yoke clamp handle (E) against pin lifter (F) and swing yoke right or left. With lifter released, the yoke automatically stops at four 90° positions.

FIG. D

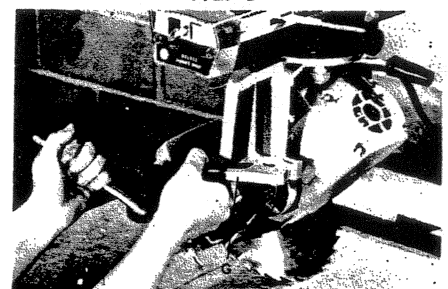

Saw Tilts for Bevel Cuts

Elevate the arm 2 1/2 inches (18 turns). Pull handle (G) and tilt to the desired angle. With the handle released, the bevel locating pin automatically locates popular 0°, 45°, and 90° bevel positions. When desired bevel angle is obtained, push clamp handle (G) and lock bevel.

NOTE: Always leave the anti-kickback assembly in place. Adjust it to just clear the workpiece in crosscutting operations and about 1/8" below the top of the workpiece during all ripping operations. Observe caution tag on guard - do not rip from anti-kickback end. Anti-kickback with spreader is available. See page 19 for catalog number.

FENCE LOCATIONS

Position (A) is used for most cutoff and narrow ripping operations. Position (B) is used for maximum width ripping. Position (C) is used to achieve extra cutoff capacity in thin work. To achieve this position on Model 7740 & 7779 rip a 1 5/8" wide strip off the spacer board and place this piece between guide fence and front board.

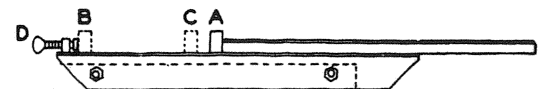

TYPICAL CUTS WITH A RADIAL ARM SAW

(SEE PAGE 14 FOR FIGURES A, B, C, D)

CAUTION FOR PURPOSES OF CLARITY THE LOWER GUARD HAS BEEN OMITTED FROM THE PHOTOGRAPHS INSIDE THIS MANUAL. HOWEVER, ALL CUTS MUST BE MADE WITH BOTH THE UPPER & LOWER GUARDS IN PLACE.

NOTE
ALWAYS WEAR GOGGLES. WEAR DUST MASK IF OPERATION IS DUSTY.

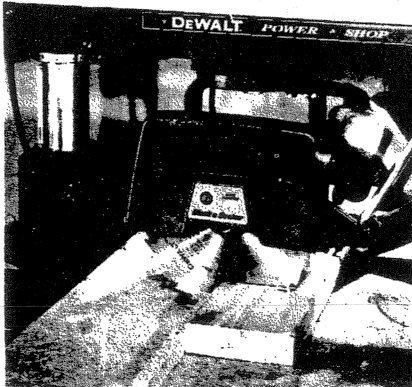

CROSS CUT

Read Fig. A. Set Arm at right angle to the guide fence, at 0° on the miter scale. With the miter latch in column slot at 0° position, securely lock arm with arm clamp handle. Place material on work table, against guide fence, draw saw blade across for the cut just far enough to sever wood. Do not bring saw blade completely through the wood. After completing cut, return saw blade behind guide fence.

The model 35010 "Roller Head Stop" accessory is available for use as an adjustable cross cut stop to prevent motion of the blade beyond the position necessary to complete the cut when performing repetitive cutting operations.

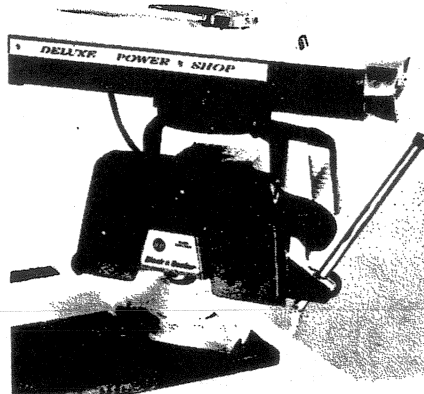

MITER

Pull arm clamp handle and swing into desired angle shown on miter scale. The miter latch locates the popular left hand and right hand angles automatically. Push clamp handle to lock the arm. Cutting action same as cross cut.

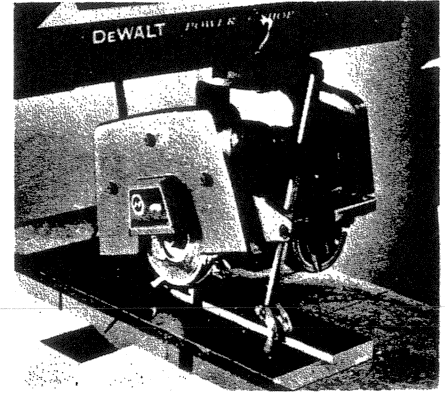

PLOUGH

This operation is done with dado head in RIP position. Lower dado head for depth of cut desired, then lock carriage securely against machine arm. Be sure to adjust guard on infeed side, lower anti-kickback assembly to hold material. When starting cut, hold material firmly down on table and back against guide. Feed evenly. Never feed material from side on which anti-kickback device is located.

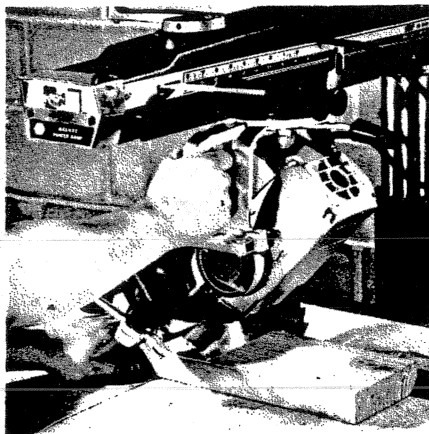

BEVEL CUT OFF

Read Figs. B and D. Start in cross cut position. Elevate the saw by rotating crank. Release bevel clamp handle and tilt motor in yoke to angle desired on bevel scale. Locating pin quickly locates 0°, 45°, and 90° positions. If any other angle is desired, bevel clamp will hold motor in position.

CAUTION Prevent the blade from contacting the base. 7730, 7740, 7770 & 7779: at angles of greater than 45°, tilt the guard slightly so that the rear of the guard hits the base. 7780: turn the bevel stop (located on the rear leg of the yoke) to a vertical position. Return stop to a sideways position when not bevel cutting.

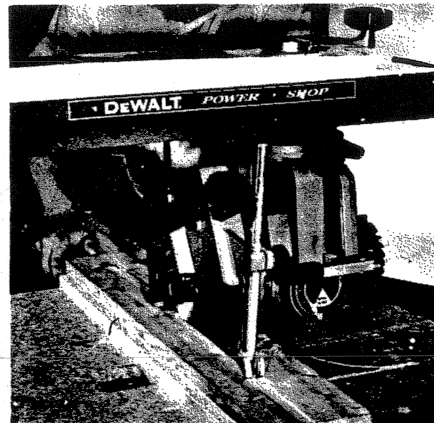

IN-RIP AND OUT-RIP

Read Fig. C. Start with arm locked in cross cut position. Pull out motor to end of arm. Pull yoke clamp handle against pin lifter. Revolve motor 90°, right or left, for out-rip or in-rip position, and lock yoke clamp handle. Locate saw for desired width of rip, using rip scale, and lock saw carriage by tightening rip lock against side of arm. Adjust guard so that infeed end almost touches material. Lower anti-kickback assembly so that fingers are approximately 1/8 inch lower than material. Slide the piece of material to be cut under anti-kickback fingers. Try pulling material in opposite direction. The anti-kickback fingers should grab it, if they do not readjust anti-kickback assembly. With material against guide strip, feed evenly into saw blade; give it a chance to cut. **DO NOT FORCE. DO NOT FEED FROM ANTI-KICKBACK SIDE OF GUARD. FOLLOW INSTRUCTIONS ON CAUTION TAG.**

Anti-kickback with spreader. See accessory page 19 for catalog number.

OPERATING INSTRUCTIONS for Anti-kickback Spreader

1. Disconnect the electrical power.

RIPPING

1. Rotate the adjusting screw to center the splitter blade in the kerf made by the blade.
2. Adjust the upper guard to drag lightly on the top surface of the workpiece. Lock it securely in this position.
3. Lower the splitter and kickback until the kickback fingers are about 1/8" below the top surface of the workpiece. Lock it securely in this position.
4. Slide the workpiece under the kickback fingers in the normal rip direction. Try to pull the workpiece backwards. If the fingers do not prevent backwards movement repeat step 3.

CROSS-CUTTING

1. Adjust the splitter and kickback so that the splitter blade just clears the fence and workpiece. Clamp it in this position. This provides blade guarding from the front direction.

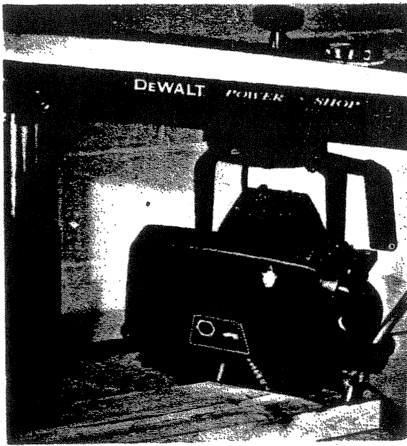

COMPOUND MITER

Read Figs. A, B, and D. Start in bevel cut-off position. Pull arm clamp handle. Swing the arm into desired miter position, usually 45° or in between angles, then relock arm clamp handles. Pull saw across for miter cuts. The compound miter cut is simply a combination bevel and miter cut.

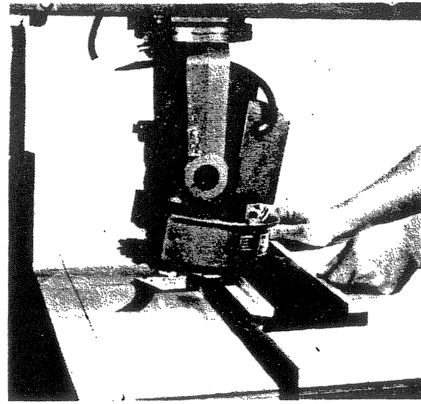

RABBET

Re-read Figs. B, C, and D. First, elevate arm until motor locates in 90° vertical position. Place shaper guard over dado head. Swivel motor into rip position so that guard sets above material. Use column crank, also rip lock to set dado for cut desired. Feed material evenly, firmly against guide. Tilt motor for bevel rabbet cuts.

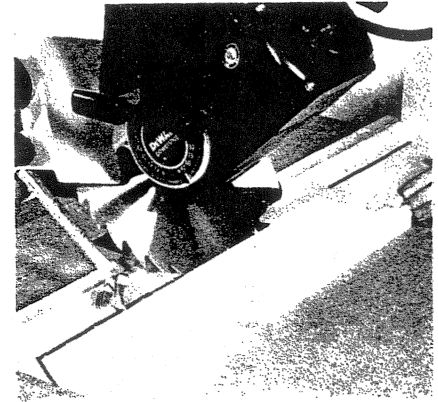

BEVEL RIP

Read Figs. B, C, and D. Start in bevel cross-cut position as described above. Now, place the saw into rip position and (using rip lock) lock securely against arm at desired point. Be sure to lower guard at in-feed position, adjust the anti-kickback device and then use a wood "pusher" board to further prevent kickback.

CAUTION

FOR PURPOSES OF CLARITY THE LOWER GUARD HAS BEEN OMITTED FROM THE PHOTOGRAPHS INSIDE THIS MANUAL. HOWEVER, ALL CUTS MUST BE MADE WITH BOTH THE UPPER & LOWER GUARDS IN PLACE.

NOTE

ALWAYS WEAR GOGGLES. WEAR DUST MASK IF OPERATION IS DUSTY.

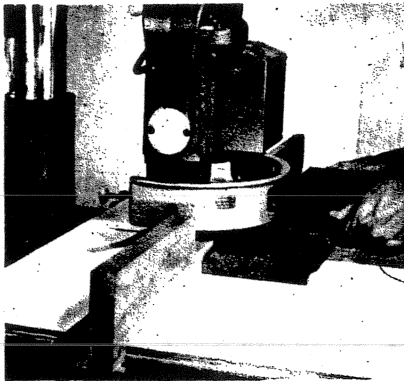

SHAPE

Place shaper cutter on motor arbor; cover with shaper guard. Now, set up the machine in the same position as RABBET. Set shaper cutter for the profile desired. Lock saw carriage securely, adjust shaper guard so that it just clears the material. Feed the material firmly and evenly into the shaper cutters. Maintain positive pressure.

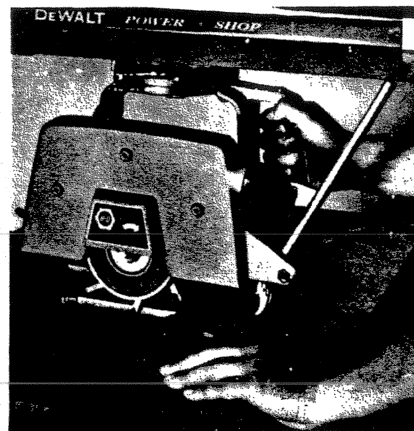

DADO

Replace saw blade with dado head. Use for across or angle dado cuts same as saw blade. When determining depth of cut; simply lower dado until it just touches top of material. Then lower dado head as desired. Each full turn equals 1/8 inch, one-half turn 1/16 inch, etc. Wide dado cuts can be made by making successive passes across the material.

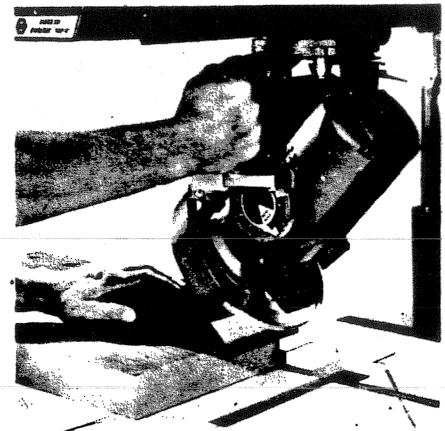

DISC SANDER

Remove arbor nut. Leave both collars in place and thread disc onto arbor. Locate disc sander wherever desired on machine. For bevel and surface sanding only, place shaper guard over the disc sander. For finish work on angles, use work support fixture. For surface sanding tilt the disc sander into vertical position. Feed the material evenly for best results. Use finer paper for final finish.

ALIGNMENT GUIDE FOR ACCURATE CUTTING

It is important to realize that an improperly adjusted saw just will not yield the accurate cuts desired. If the machine seems to cut inaccurately, its adjustments and alignments should be checked.

The following guide is listed for your convenience. However, *changing one adjustment will affect another, so it is best to perform all of the alignment procedures when correcting any one problem.*

ALIGNMENT GUIDE FOR ACCURATE CUTTING





PROBLEM	POSSIBLE CAUSE	SOLUTION	
1. Saw will not make a square cross cut or a good 45° miter cut.	Arm is not perpendicular to guide fence.	Adjust cross cut travel with guide fence.	
	Arm has excessive play at end.	Tighten adjusting screws.	
	Column is loose in base.	Make proper adjustment.	
	Too much play between arm and column.	Make proper adjustment.	
	Roller head too loose in arm.	Adjust roller head correctly.	
	Yoke too loose when clamped to roller head.	Adjust yoke clamp handle.	
	Saw dust between lumber and guide fence.	Keep table top clean.	
	Table not parallel with arm.	Make proper adjustment.	
	Guide fence not straight. Rear edge of fixed board not straight.	Replace fence. Sand or replace.	
	2. Lumber has a tendency to walk away from fence when ripping or ploughing.	Saw blade is not parallel with fence.	Make heel adjustment.
Arm not perpendicular to guide fence.		Adjust cross cut travel with guide fence.	
3. Saw stalls when ripping or ploughing.		Dull blade or cutters.	Sharpen or replace blade.
		Fence not straight.	Replace Fence.
		Feed rate too fast.	Slow feed rate.
		Wrong blade.	Use correct blade.
		Column too loose in base.	Make proper adjustments.
		Too much play between arm and column.	
		Roller head too loose in arm.	
		Yoke loose when clamped to roller head.	
	Saw dust between lumber and fence.	Keep table top clean.	
	4. Saw blade scores lumber, not giving a good finished cut.	Saw blade is heeling.	Make heel adjustment.
Column too loose in base.		Make proper adjustments.	
Too much play between arm and column.			
Roller head loose in arm.			
Yoke too loose when clamped to roller head.			
Bent blade or dull.		Replace blade.	
Not feeding saw properly.		Draw saw blade across lumber with a slow and steady pull.	
Using improper blade for finish cut desired.		Change blade.	

PROBLEM	POSSIBLE CAUSE	SOLUTION
5. Saw blade or Dado blades tend to push lumber to one side when cross cutting.	Saw blade is heeling.	Make heel adjustment.
	Column too loose in base.	Make proper adjustments
	Too much play between arm and column.	
	Roller head too loose in arm.	
	Yoke too loose when clamped to roller head.	
	Fence not straight.	Replace.
	Dull blade or cutters.	Replace or sharpen.
6. Cut depth varies from one end of stock to the other.	Table top not parallel with arm.	Adjust table top parallel with arm.
	Column too loose in base.	Make proper adjustments.
	Too much play between arm and column.	
7. 45° bevel cut not accurate.	Saw blade not perpendicular to table top.	Make saw blade adjustment.
	Column too loose in base.	Make proper adjustments.
	Too much play between arm and column.	
	Roller head too loose in arm.	
	Yoke too loose when clamped to roller head.	
	Bevel clamp handle loose.	
	Table top not parallel with arm.	
8. Saw tends to advance over lumber too fast.	Roller head bearings not properly adjusted.	Adjust roller head bearing to arm.
	Dull blade.	Replace or sharpen.
	Not feeding saw properly.	Draw saw blade across lumber with a slow and steady pull.
9. Saw does not traverse smoothly in tracks.	Dirty tracks.	Clean.
	Bad bearing.	Replace bearing.
10. Miter scale not accurate at various miter angles.	Scale pointer not properly adjusted.	Adjust scale pointer.
11. Elevating handle slips when elevating or lowering saw.	Belt tension not sufficient.	Adjust belt tension.
	Set screw in elevating arm loose.	Tighten set screw.
	Base not adjusted properly.	Adjust base to column.
12. Clamping force not sufficient at miter angles other than 45°.	Arm clamp out of adjustment.	Adjust arm clamp.
13. Clamping force not sufficient at bevel angles other than 45°.	Bevel clamp handle too loose.	Adjust bevel clamp handle.

ATTACHMENTS & ACCESSORIES

Even more RADIAL SAW versatility with these attachments . . .

RADIAL SAW SAW BLADES All blades listed have 15.9 mm (5/8") arbor hole.

	Cat. Number	Size	Type	No. of Teeth	Quality
	35025	203.2 mm (8")	Combination, Chisel Tooth	22	Standard
	R2919	203.2 mm (8")	Plywood Veneer, Taper Ground	176	Standard
	R997	228.6 mm (9")	Combination, Chisel Tooth	28	Premium
	R1011	228.6 mm (9")	Planer, Hollow Ground	65	Premium
	R1013	254.0 mm (10")	Planer, Hollow Ground	75	Premium
	R1014	254.0 mm (10")	Plywood Veneer, Taper Ground	200	Premium
	R1041	254.0 mm (10")	Combination, Chisel Tooth	30	Premium
	R1426	254.0 mm (10")	Rip	36	Standard
	R2010	254.0 mm (10")	Combination, Novelty Tooth	60	Standard
	30010	254.0 mm (10")	Combination, Novelty Tooth	28	Standard
	CARBIDE SAW BLADES				
	R989	254.0 mm (10")	Combination	8	
	30101	254.0 mm (10")	Combination	40	

RADIAL SAW Legs

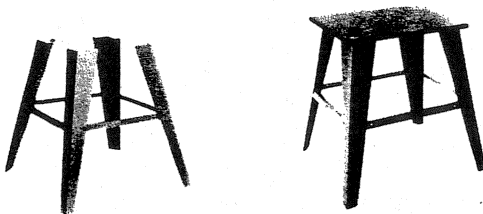

R1201 Leg Stand. For models 7730, 7740, 7770.

35021 Deluxe Machine Stand. Use with DeWalt 7700, 7710, 203.2 mm (8") Saw and B&D Bench Grinders and 7717 Miter Box. A stable work shop bench for many uses. Work surface 584.2 mm x 476.3 mm (23" x 18 3/4") high. Rubber foot grommets.

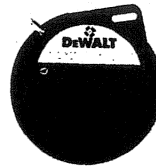

Automatic Return Device. Fastens to rear of machine arm. Returns saw carriage to rear position. 35026 fits 8" radial arm saw, plus 10" and 12" Radial Saws.

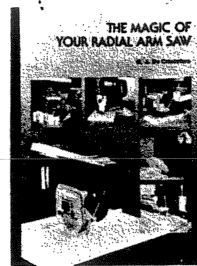

35601 "The Magic of Your Radial Arm Saw." 310 pages of highly descriptive ideas and illustrations.

R1516 Splitter and Anti-Kickback Device. For all 254 mm (10") radial arm saws.



R1205 Adjustable Cutoff Gauge. Use with any radial arm saw. Clamps to fence for repeated accurate length cutting. Fine adjusting screw provides precise setting for exact length.

Lower Blade Guards. Free floating device rides over stock being cut.

35017. 254 mm (10") New Style lower blade guard, fits all 254 mm (10") DeWalt models.



35010 Roller Head Stop. Mounts on arm of 254 mm (10") and 305 mm (12") machines to limit travel of roller head to any desired cut-off length.

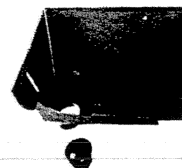

32000 Saw Dust Catcher. Sturdy plastic unit collects dust in crosscut, miter and bevel positions. Fits 7730, 7740, 7770, 7779 machines and fits other models if modified.

RADIAL SAW Shape & Joint

Make finished edges for glue jointing long boards. Edge & surface shape with many different knife sets for decorative mouldings and cabinet making, panel raising and other special woodworking effects.



30025 Shaper / Jointer Fence. Converts saw for precise shaping and jointing operations. In feed fence has 1/32" & 1/16" adjustments.

Deluxe Shaper & Knives Yield Finest Quality Work.

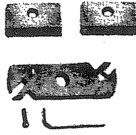

30024 Jointer Head & Knives Set includes 2-Knife Shaper Head (R6480): 127 mm (5") long, 38.1 mm (1 1/2") wide, 15.88 mm (5/8") arbor hole and 50.8 mm (2") Jointing/Surfacing and Panel Raising Knives (R6477).

R6480 2-Knife Shaper Head. 127 mm (5") long, 38.1 mm (1 1/2") wide, 15.88 mm (5/8") arbor hole.



R3076



R6477



R6478

Sets of 2 Knives—Self Aligning. 6.4 mm-9.6 mm (1/4"-3/8") thick, 25.4 mm-38.1 mm (1"-1 1/2") long. High speed steel with one hole and held by 6.4 mm (1/4") socket screw.

R3076 8 mm (5/16") Bead and Cove Knives

R6477 50.8 mm (2") Jointing/Surfacing and Panel Raising Knives

R6478 Cabinet Door Lip Knives, 9.6 mm (3/8") radius, 7° rake

Economical Starter Set and Knives



R6501 3-Knife Shaper Head Set. 1 R6500 Head; 1 R6505 Glue Joint Knives; 1 R6512 Universal Bead Knives; 1 R6515 Cabinet Door Lip Knives; 1 R6517 8 mm (5/16") Bead and Cove Knives.

R6500 3-Knife Shaper Head for Radial and Table Saws, 15.9 mm (5/8") arbor hole.



R6505

R6506

R6512



R6514

R6515

R6517



R6518

R6519

R6520



R6521

R6522

R6524

Sets of 3 Knives:

R6505 Glue Joint Knives

R6506 Ogee Casing Knives

R6512 Universal Bead Knives

R6514 Panel Cupboard Door Knives

R6515 Cabinet Door Lip Knives

R6517 8 mm (5/16") Bead and Cove Knives

R6518 25.4 mm (1") Straight Knives

R6519 Tongue Knives

R6520 Groove Knives

R6521 6.4 mm (1/4") and 12.7 mm (1/2") Quarter Round Knives

R6522 Triple 6.4 mm (1/4") Bead Knives

R6524 Base Mold Knives



34003 Tool Guard. Replaces standard blade guard for shaping, jointing, disc sanding and planing operations. Will accommodate tools up to 203.2 mm (8") dia.

RADIAL SAW Saber Saw



30020 Saber Saw. Does curve work the fast easy way in wood, plastic, metal. Complete with blade.

R8028 Saber Saw Blades. Consists of one each: Fine, Medium, Coarse.

RADIAL SAW Rout

35500 Router Attachment. Holds router motor for overarm routing applications. Ideal for variety work. Uses most Router motors.



R1208 9.6 mm (3/8") Drill chuck w/key fits right hand arbor on models 7730, 7740, 7770, 7779 for horizontal drill. A must for dowel jointing.



RADIAL SAW Plane & Sand

Rotary planers surface and size boards. Sanders finish surfaces with either straight or curved edges.

R6380 Rotary Planer (includes knives and wrench). Surface planes. Excellent for thickness sizing, panel raising.

R6383 Knife Set. 2 Knives for R6380

Disc Sander. 15.9 mm (5/8") L.H. thread.

R7470 203.2 mm (8") dia. Sander Disc Set (includes bevel edge disc, one 203.2 mm (8") dia. pressure-sensitive sandpaper disc No. 60 grit). Fast material removal. Surface, end grain and bevel sanding.

30016 6 assorted 203.3 mm (8") pressure-sensitive sandpaper discs (1 No. 50, 2 No. 60, 3 No. 80 grits).

Drum Sanders.

30092 3" (76.2 mm) dia., 76.2 mm (3") long Drum Sander, 15.9 mm (5/8") L.H. thread. Fits arbor shaft of all 254 mm (10") and 305 mm (12") models for straight and curved edges up to 50.8 mm (2") thick.

30091 2" dia. (50.8 mm) Drum Sander, 76.2 mm (3") long, 15.9 mm (5/8") L.H. thread. Fits arbor shaft of all 254 mm (10") and 305 mm (12") models for medium radius curves and delicate sanding.

30090 1" dia. (25.4 mm) Drum Sander, 76.2 mm (3") long, 15.9 mm (5/8") L.H. thread. Fits arbor shaft of all 254 mm (10") and 305 mm (12") models for small radius curves and delicate sanding.

RADIAL SAW Dado

These great DADO SETS cut uniform slots, grooves, half laps, drawer corners, rabbet cuts, with Spacers and Chippers Assure Finest Quality Cut and Precision over Longest Life.

R6024 152.4 mm (6") Dado Head Set. Flat Ground (2 Blades, 4 Chippers 3.2 mm (1/8"), 1 Chipper 1.6 mm (1/16") 15.9 mm (5/8") bore.

R6001 152.4 mm (6") Dado Head Set. Hollow Ground (2 Blades, 4 Chippers 3.2 mm (1/8"), 1 Chipper 1.6 mm (1/16") 15.9 mm (5/8") bore.

R6025 203.2 mm (8") Dado Head Set. Flat Ground (2 Blades, 4 Chippers 3.2 mm (1/8"), 1 Chipper 1.6 mm (1/16") 15.9 mm (5/8") bore.



MOTOR OVERLOAD PROTECTION

Your Saw Motor is equipped with a manual-reset overload protector. If the protector "trips" and stops the motor, take the following steps:

1. Press the "OFF" button on the front of the arm.
2. Allow the motor to cool, and then press the red RESET button. If you do not hear a "click", allow the motor to cool further until you do hear a "click" when the button is pressed.
3. After the reset is accomplished, the saw may be started by pressing the "ON" button.

TROUBLE SHOOTING CHART—MOTOR

TROUBLE	PROBABLE CAUSE	REMEDY
Motor will not run.	Protector open; circuit broken.	Reset protector by pushing on red button (indicated by audible click).
	Low voltage.	Check power line for proper voltage.
Motor will not run and fuses "BLOW."	Short circuit in line cord or plug.	Inspect line cord and plug for damaged insulation and shorted wires
	Short circuit in junction box, or loose connections.	Inspect all terminals in motor junction box for loose or shorted connections.
Motor fails to develop full power. (Power output of motor decreases rapidly with decrease in voltage at motor terminals.)	Power line overloaded with lights, appliances and other motors.	Reduce line load.
	Undersize wires or circuit too long.	Increase wire sizes, or reduce length of wiring.
	General overloading of power company's facilities. (In many sections of the country, demand for electrical power exceeds the capacity of existing generating and distribution systems.)	Request a voltage check from the power company.
	Incorrect fuses in power line.	Install correct fuses.
Motor starts slowly or fails to come up to full speed.	Low Voltage — will not trip starting relay.	Correct low voltage condition.
	Starting relay not operating.	Replace relay.
Motor overheats.	Motor overloaded.	Correct overload condition.
	Improper cooling. (Air circulation restricted through motor due to sawdust, etc.)	Clean out sawdust to provide normal air circulation through motor.
Starting relay in motor will not operate.	Burned relay contacts (due to extended hold-in periods caused by low line voltage, etc.)	Replace relay and check line voltage.
	Open relay coil.	Replace relay.
	Loose or broken connections in motor terminal box.	Check and repair wiring.
Motor stalls (resulting in blown fuses or tripped circuit breakers).	Starting relay not operating.	Replace relay.
	Voltage too low to permit motor to reach operating speed.	Correct the low line voltage condition.
	Fuses or circuit breakers do not have sufficient capacity.	Replace fuses or circuit breakers with proper capacity units.
Frequent opening of fuses or circuit breakers.	Motor overloaded.	Reduce motor load.
	Fuses or circuit breakers do not have sufficient capacity.	Replace fuses or circuit breakers.
	Starting relay not operating (motor does not reach normal speed.)	Replace relay.

For Wiring Diagram see Parts Bulletin.

UNIT IDENTIFICATION

No. 740

10" RADIAL ARM SAWS

MODEL NO	Type	VOLTAGE	60 cy.	50 cy.	1 ph.	MODEL NO.	Type	VOLTAGE	50/60 cy.	1 ph.
7740/3421	Type 3	120V	60 cy.		1 ph.	7740-06/3421-06	Type 3	120V	50/60 cy.	1 ph.
7740-01	Type 3	220V	50 cy.		1 ph.	7740-07	Type 3	240V	50 cy.	1 ph.
7740-03/3421-03	Type 3	220V	50 cy.		1 ph.	7740-08/3421-08	Type 3	100V	50/60 cy.	1 ph.
7740-04/3421-04	Type 3	240V	50 cy.		1 ph.					

SEE VME DATA BULLETIN
#5001 REPAIR METHOD

Bulletin No. 8330-2

Base, Column & Elevating Screw

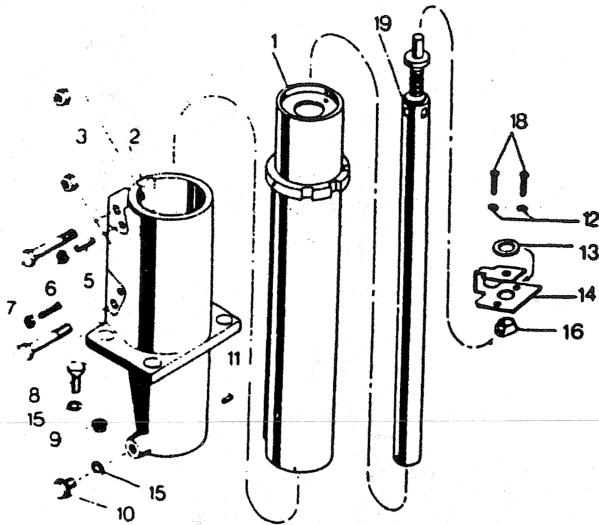

Identification	Description	Quantity	Part No.
5	Flat Pt. Set Screw (1/4-20 x 1 1/8")	2	80935 122147
6	Hex Nut (1/4-20)	2	83944
7	Hex Hd. Cap Screw (5/16-18 x 2 1/2")	2	72382
8	Hex Hd. Cap Screw (3/8-16 x 1 1/4")	4	82105
9	Hex Nut (3/8-16)	4	84180
10	Screw (3/8-16 x 3/4")	2	82098
11	Roll Pin (1/4 x 3/4")	1	82033
12	Lock Washer (1/4")	2	99389-06 84173
13	Washer	1	121451 72159
14	U Bracket SA (Includes 16)	1	71913 122769
15	Lock Washer	6	82510 415
16	Bracket Bushing	1	81270
18	Rd. Hd. Mach. Screw (1/4-20 x 1") (Philips)	2	82286
19	Elevating Mechanism	1	81233-02

Identification	Description	Quantity	Part No.
1	Column	1	81232
2	Base	1	84505-02
3	Jam Nut (5/16-18)	2	81956

Arm

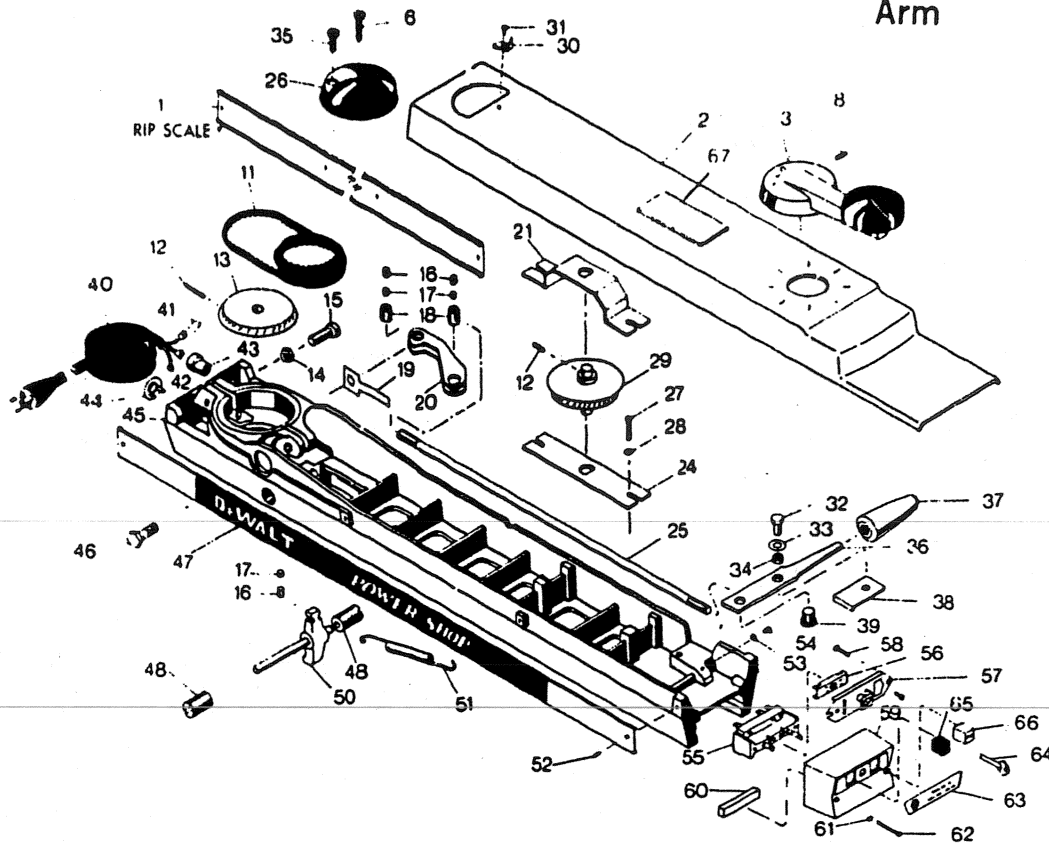

Identification	Description	Quantity	Part No.	Identification	Description	Quantity	Part No.
1	Rip Scale (Cat. Nos. 7740, 3421, 7740-03, 3421-03, 7740-04, 3421-04, 7740-06, 3421-06, 7740-08, 3421-08)	1	121799	39	Pivot Pin	1	81259
	Rip Scale (Cat. No. 7740-01, 7740-07)	1	96945	40	Cord & Plug (include 41, 42) (7740-01, 7740-03)	1	81373-01
2	Arm Shroud	1	96945-01	41	Spade Connectors	2	93993-03
3	Elev. Arm Assembly (Include 8)	1	71917-02	42	Lead Terminal	1	80291
4	Shim Washer	2	62518	43	Cord Bushing (7740-01, 7740-03)	1	34289
6	Oval Hd. Mach. Screw	1	72656	44	Adaptor (48822, 88095) (7740-01, 7740-03)	1	48822
8	Cup Pt. Set Screw (1/4-20 x 1/2")	1	80648	45	Arm	1	88095-01
11	Timing Belt	1	81273	46	Hex Hd. Cap Screw (3/8-16 x 2")	1	81238-02
12	Set Screw	1	72160	47	Escutcheon Plate L.S.	1	80165
13	Timing Belt Sprocket	1	72087-01	48	Miter Adj. Screw	2	68193
14	Jam Nut (5/16-18)	2	80467	50	Miter Latch & Pin	1	83122
15	Soc. Hd. Cap Screw (5/16-18 x 1-1/4")	2	82172	51	Miter Latch Spring	1	96892
16	Cup Pt. Set Screw (1/4-20 x 1/4")	4	82387	52	Pan Hd. Thd. forming Screw (6-32 x 1/4") (Phillips)	8	81266
17	Set Screw Slug	4	103522	53	External Lockwasher (#8)	1	80488
18	Clamp Lever Pin	2	81261	54	Pan Hd. Taprite Screw (8-32 x 3/8")	1	33985
19	Wear Spring	1	81263		Switch Assembly (includes 55 through 58 and 65, 66)	1	80489
20	Arm Clamp Cam	1	86526	55	Switch	1	203885-01
21	Upper Bracket	1	71916	56	Switch Slide Lock	1	203194-01
24	Lower Bracket	1	71915	57	Switch Support & Stop	1	207061
25	Clamp Rod	1	81260	58	Rd. Hd. Self Tap Screw (6-32 x 3/8")	1	203358
26	Miter Scale	1	71918	59	Arm End Cap (Includes 60 and 63)	2	83054
27	Rd. Hd. Machine Screw (10-24 x 1/2") (Phillips)	2	82721	60	Bumper	2	80894
28	Flat Washer (1/2 O.D. x 7/32" I.D.)	2	80670-30251	61	External Lockwasher (#10)	2	203065
29	Shaft & Sprocket	1	71911	62	Fill Hd. Mach. Screw (10-24 x 1-1/2") (Phillips)	2	99476-04
30	Pointer	1	72219	63	Name plate	1	80826
31	Pointer Screw	1	80488	64	Key	1	96951
32	Hex Hd. Cap Screw (5/16-18 x 5/8")	1	82144	65	Switch Button (Black)	1	85283
33	Washer	1	80457	66	Switch Button (Orange)	1	81371
34	Spacer	1	81257		Cable Sleeve Part Not Shown	1	81371-01-02
35	Pan Hd. Screw (5/16-18 x 1")	1	99250-18	67	Instruction Label	1	83705
36	Control Handle	1	81255-01				96937-122028
37	Handle Grip	1	80066				
38	Handle Guard	1	81258				

Cat. Nos. 7740/3421 series Type 3
No. 740 10" RADIAL ARM SAW

Bulletin No. B330-2

Table Top & Table Frame

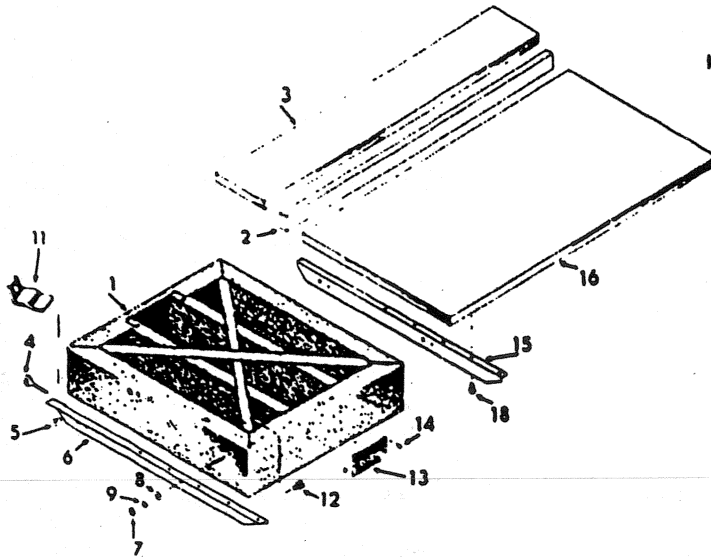

Identification	Description	Quantity	Part No.
1	Table Frame	1	66312-02 ⁰⁴
2	Guide Fence	1	96615-01
3	Back Board	1	96615
4	Thumb Screw	2	80455
5	Eyelet	2	80050
6	L. H. Cleat	1	72091-01
7	Hex Nut (3/8-16)	4	84180
8	Flat Washer (3/8")	4	80674
9	Lockwasher (3/8")	4 ¹⁵	82510
11	Bracket	2	72086
12	Sq. Hd. Mach. Bolt (3/8-16 x 3/4")	4	81911
13	Machine Name Plate	1	85301
14	Drive Screw (#4 x 3/16")	4	12122
15	R. H. Cleat	1	72091
16	Fixed Table Board	1	96616
18	Table Screws	10	**201287

*Replacement Guide Fence may be made from Standard 1" x 2" Lumber.

**Some units built with 6 table screws.

PARTS NOT SHOWN	{	No. 99056-03	3/32"	Hex Wrench
		No. 83104	1/8"	Hex Wrench
		No. 99056-11	1/4"	Hex Wrench

ASSEMBLY OF LOWER GUARD TO UPPER GUARD

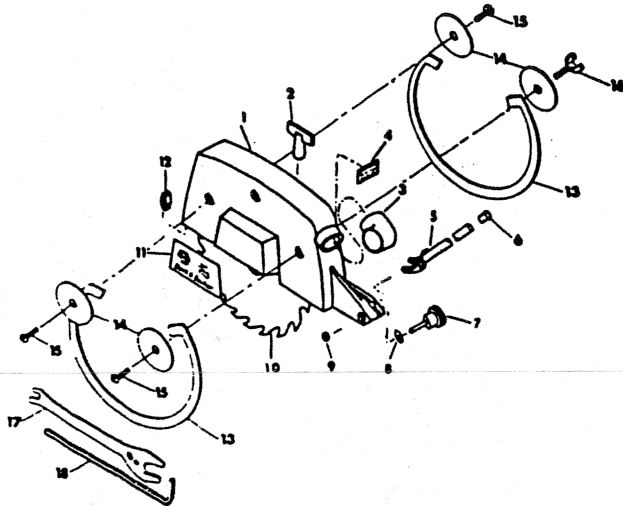

1. Hang outer ring (13) on bosses located on upper guard and mount two guard retainers (14) using two self-tapping screws (15) into pre-drilled holes on outer side of guard. Tighten screws to seat support washers.
2. Hang inner ring (13) on bosses located on guard and mount two guard retainers (14) using one self-tapping screw (15) and one thumb screw (16) on inner side of guard. Thumb screw to be used in boss nearest to kickback assembly. Tighten screw and thumb screw to seat support washers.

NOTE: It is not necessary to remove guard and blade from motor to remove or re-install the ring. To change blades remove thumb screw and washer by hand and the inner ring is easily removed. The upper guard with outer ring can be removed allowing blade to be changed.

GUARD ASSEMBLY

Identification	Description	Quantity	Part No.	Identification	Description	Quantity	Part No.
1	Guard (Includes 4, 11 & 12)	1	203272-03 ¹³	10	Saw Blade (10" Combination Chisel Tooth)	1	R1041
2	Wing Nut	1	70474	11	Name Plate	1	96934
3	Dust Spout	1	80466	12	Guard Clip	1	201404 ⁰⁹
4	Caution Plate	1	80126	13	Lower Guard	2	96622-02
5	Kickback Assembly	1	70477-02	14	Guard Retainers 122341 122232	4	96621-02
6	Cap	1	80534	15	10-24 x 3/8 RH Self-Tap Screw	3	84638
7	Kickback Clamp	1	80085-01	16	10-24 x 3/8 Thumb Screw	1	96692
8	Shim Washer	1	80457	17	Wrench	1	80137-01
9	Hex Jani Nut (5/16-18)	1	80467	18	Allen Wrench (5/16 Hex)	1	80138

Cat. Nos. 7740/3421 series Type 3

No. 740 10" RADIAL ARM SAW

Bulletin No. 8330-2

Rollerhead Assembly

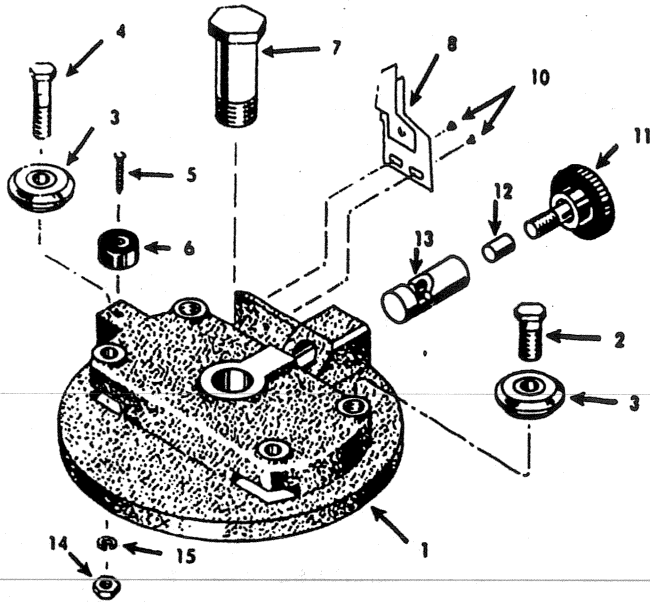

Identification	Description	Quantity	Part No.
1	Rollerhead	1	81331-02
2	Hex Hd. Cap Screw ($\frac{3}{8}$ -16 x 1")	2	82102
3	Bearing	4	81004
4	Bearing Shaft (Eccentric)	2	80461
5	Drive Screw (#6 x $\frac{3}{8}$)	1	82229
6	Bumper	1	80525
7	King Bolt	1	70475
8	Pointer (Out-Rip) (In-Rip) 121914	1	83822-02
10	Pan Hd. Taptite Screw (#6 x $\frac{1}{4}$ ")	2	80488
11	Rip Lock Knob	1	81368-80085-01
12	Rip Lock Slug	1	81333
13	Rip Lock	1	81332
14	Hex Nut ($\frac{1}{2}$ -24)	2	80470
15	Lock Washer ($\frac{1}{2}$)	2	84319

Yoke Assembly

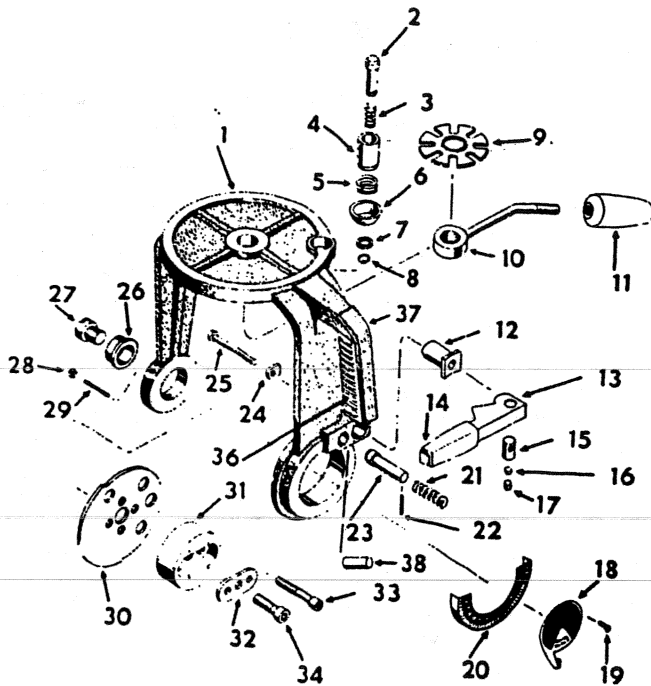

Identification	Description	Quantity	Part No.
1	Yoke (Includes 4)	1	81378-05
2	Index Pin	1	81341
3	Latch Spring	1	81324
4	Locating Bushing	1	81340
5	Cup Spring	1	81342
6	Index Cam Cup	1	81339
7	Washer	1	81337
8	Snap Ring	1	39645
9	Adjuster	1	80464
10	Yoke Clamp	1	203751
11	Handle Grip	1	80066
12	Bevel Clamp Bushing	1	71727
13	Bevel Clamp Handle	1	81345-01
14	Handle Grip	1	81366-01
15	Pivot Pin	1	81357
16	Set Screw Slug	1	103522
17	Hol. Hd. Cup Pt. Set Screw ($\frac{1}{4}$ -20 x $1\frac{1}{4}$ ")	1	82387
18	Medallion Pointer	1	81355-121773
19	Pan Hd. Taptite Screw (8 x $\frac{1}{4}$ ") (Phillips)	1	80487
20	Bevel Scale 121776	1	81356-
21	Bevel Latch Spring	1	80828
22	Roll Pin ($\frac{3}{32}$ x $\frac{5}{8}$ ")	1	38454
23	Release Pin	1	81323
24	Washer	1	81358
25	Bevel Clamp Screw	1	81208
26	Trunnion Bushing	1	70476-122193
27	Support Screw	1	203111
28	Hex Nut (#10-24)	3	81953
29	Soc. Cup Pt. Set Screw (10-24 x 1")	3	80652
30	Dial Plate	1	81344
31	Dial Plate Hub	1	81361
32	Hub Washer	1	80969
33	Soc. Hd. Cap Screw ($\frac{1}{4}$ -18 x $1\frac{1}{4}$ ")	2	82172
34	Spec. Screw	1	81014
36	Yoke Handle Grip LH	1	81363-03
37	Yoke Handle Grip RH	1	81363-02
38	Bushing	1	81354

Cat. Nos. 7740/3421 series Type 3
No. 740 10" RADIAL ARM SAW

Bulletin No. 83302

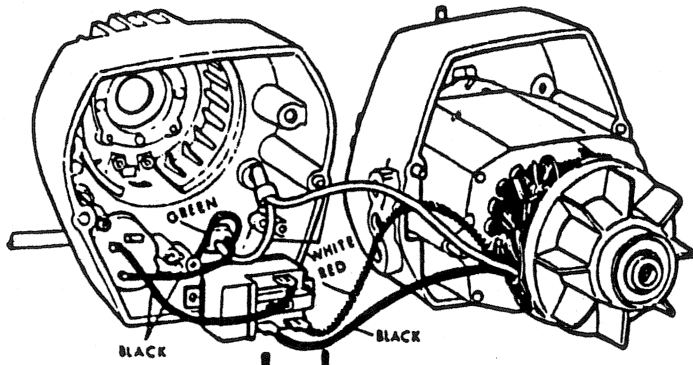

MOTOR WIRING

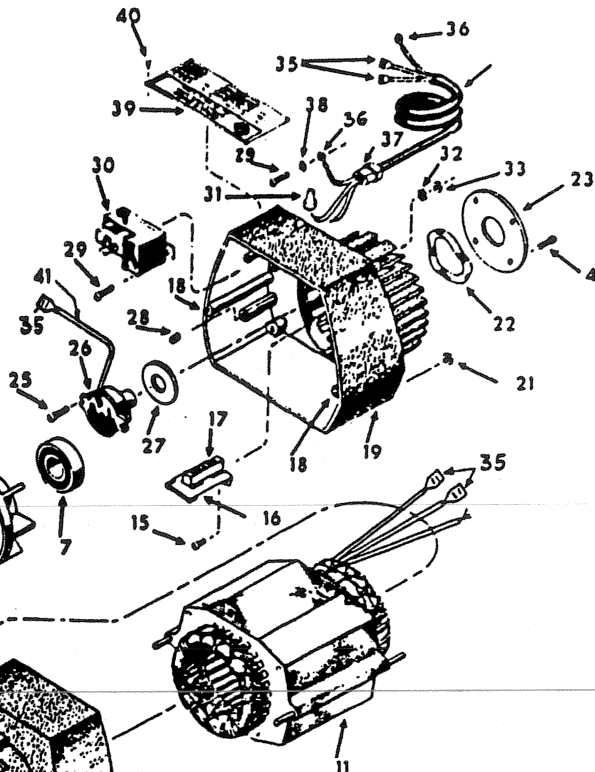

1 PH
Motor Assemblies

Identification	Description	Quantity	Part No.
1	Nut (Arbor)	1	80109
2	Collar (Arbor)	2	80465 122166
3	Spacer	1	80105
4	Rd. Hd. Screw (10-24 x 1/2")	8	80162
5	Cover Plate	1	80104-02
7	Ball Bearing (Arbor)	2	80110
8	Tie Rod	4	80423
9	Guard Stud	1	539807 121253
10	Front Motor Housing	122148-01	72190-01 679243-515
11	Stator (120v 60 cy 1 PH)	1	80413-51 721958-51
679241-47	(240v 50 cy 1 PH)	1	80413-47 721958-47
679242-48	(220v 50 cy 1 PH)	1	80413-48 721958-48
679245-61	(120v 50/60 cy 1 PH)	1	80413-61 721958-61
	(120v 50 cy 1 PH)	1	80413-41
679244-60	(100v 50/60 cy 1 PH)	1	80413-60
12	Rotor	1	80431
13	Fan	1	66141
15	Rd. Hd. Screw (6-32 x 3/8")	2	5533
16	Brake	1	80434
17	Brake Push Button	1	70478
18	Dowel Pin	2	80424
19	Rear Motor Housing	1	80411-02
20	Lockwasher (#8)	4	36700
21	Hex Nut (8-32)	4	407
22	Load Spring	1	99082-02
23	Rear Cover Plate	1	80417-02
25	Rd. Hd. Taptite Screw (8-32 x 1/2")	2	80440

Cat. No.	Part No.	Description
New		
7740/3421	70589-51	120v 60 cy
7740-01	70589-48	220v 50 cy
7740-03/3421-03	70589-48	220v 50 cy
7740-04/3421-04	70589-47	240v 50 cy
7740-06	70589-61	120v 50/60 cy
7740-07	70589-47	240v 50 cy
7740-08	70589-60	100v 50/60 cy

(Includes items 4 through 41)

Identification	Description	Quantity	Part No.
25	Overload Protectors, 1 PH		
	(120v 60 cy & 120v 50 cy, 120v 50/60 cy)	1	70572
	(220v 50 cy & 240v 50 cy)	1	70572-01
	(100v 50/60 cy)	1	71732-02
	(120v 50/60 cy)	1	70572-02
27	Felt Washer	1	545012
28	Rubber Plug	2	33055
29	Rd. Hd. Taptite Screw (8-32 x 3/8")	3	55206
30	Relay		
	(120v 60 cy 1 PH) (120v 50/60 cy 1 PH) (120v 50 cy 1 PH) (100v 50/60 Cy) (220v 50 cy 1 PH & 240v 50 cy 1 PH)	1	71732
31	Wire Connector	1	71732-04
32	External Washer (#6)	1	32114-06
33	Hex Nut	2	36521
34	Motor Cable (Includes 35 and 36)	2	12226
35	Spade Connector	1	70649-01
36	Lead Terminals	2	80201
37	Cable Bushing	2	34289
38	External Washer (#8)	1	33305-445467
39	Specification Plate	1	33985
40	Drive Screw	1	96941-01-122030
41	Jumper Lead & Connector	4	3041
		1	80427

Parts Not Shown
Connection Diagram 1 -80432 122733 123180

Cat. Nos. 7740/3421 series Type 3
No. 740 10" RADIAL ARM SAW
Bulletin No. 83307 C-5